

1600XP SERIES

INSTALLATION AND OPERATION MANUAL

SINGLE PHASE - 3.6/6/8/10/14/18/22 KVA



Part # 60616-004
March 2011

Manufactured in the USA

1600XP SERIES

INSTALLATION AND OPERATION MANUAL
SINGLE PHASE - 3.6/6/8/10/14/18/22 KVA

Part # 60616-004
March 2011



Product Use and Warranty Restrictions

The Toshiba products listed in this document are intended for usage in general electronics applications (computer, personal equipment, office equipment, measuring equipment, industrial robotics, domestic appliances, etc.). These Toshiba products are neither intended nor warranted for usage in equipment that requires extraordinarily high quality and/or reliability or where a malfunction or failure may cause loss of human life or bodily injury (Unintended Usage). Unintended Usage includes atomic energy control instruments, airplane or spaceship instruments, transportation instruments, traffic signal instruments, combustion control instruments, surgical operating room or life-support equipment, all types of safety devices, etc. Unintended Usage of Toshiba products listed in this document shall be made at the customer's own risk.

NOTICE

PLEASE INFORM TOSHIBA INTERNATIONAL CORPORATION OR AUTHORIZED REPRESENTATIVE IN CASE OF INCONSISTENCIES, OMISSIONS, OR QUESTIONS.

The instructions contained in this manual are not intended to cover all of the details or variations in equipment, or to provide for every possible contingency concerning installation, operation, or maintenance. Should further information be required or if problems arise which are not covered sufficiently, contact your Toshiba sales office.

The contents of this instruction manual shall not become a part of or modify any prior or existing agreement, commitment, or relationship. The sales contract contains the entire obligation of Toshiba International Corporation UPS Division. The warranty contained in the contract between the parties is the sole warranty of Toshiba International Corporation UPS Division and any statements contained herein DO NOT create new warranties or modify the existing warranty.

Any electrical or mechanical modifications to this equipment without prior written consent of Toshiba International Corporation will void all warranties and may void the UL/CUL listing. Unauthorized modifications can also result in personal injury, loss of life, or destruction of the equipment.

QUALIFIED PERSONNEL ONLY

Qualified Personnel are those who have the skills and knowledge relating to the construction, installation, operation, and maintenance of the electrical equipment and have received safety training on the hazards involved (Refer to the latest edition of NFPA 70E for additional safety requirements).

UNINTERRUPTIBLE POWER SYSTEM (UPS)

Please complete the following information and retain for your records.

Unless otherwise specified, the warranty period for the UPS or UPS part is 36 months from the shipment date (see Toshiba International Corporation bill of lading).

Unless otherwise specified, the warranty period for a UPS battery is 24 months from the shipment date (see Toshiba International Corporation bill of lading).

JOB NUMBER	_____
MODEL NUMBER	_____
SERIAL NUMBER	_____
APPLICATION	_____
SHIPMENT DATE	_____
INSTALLATION DATE	_____
INSPECTED BY	_____

Purpose

This manual provides information on how to safely install your Toshiba International Corporation power electronics product. This manual includes a section of general safety instructions that describes the warning labels and symbols that are used throughout the manual. Read the manual completely before installing, operating, or performing maintenance on this equipment.

This manual and the accompanying drawings should be considered a permanent part of the equipment and should be readily available for reference and review. Dimensions shown in the manual are in metric and/or the English customary equivalent.

Toshiba International Corporation reserves the right, without prior notice, to update information, make product changes, or discontinue any product or service identified in this publication.

Toshiba is a registered trademark of the Toshiba Corporation. All other product or trade references appearing in this manual are registered trademarks of their respective owners.

Toshiba International Corporation shall not be liable for direct, indirect, special, or consequential damages resulting from the use of the information contained within this manual.

This manual is copyrighted. No part of this manual may be photocopied or reproduced in any form without the prior written consent of Toshiba International Corporation.

© Copyright 2011 Toshiba International Corporation
All rights reserved.
Printed in the U.S.A.

Toshiba Customer Support Center

Contact the Toshiba Customer Support Center for assistance with application information or for any problems that you may experience with your Uninterruptible Power System (UPS).

Toshiba Customer Support Center
8 a.m. to 5 p.m. (CST) - Monday through Friday
USA Toll Free (877) 867-8773
Tel (713) 466-0277
Fax (713) 466-8773

You may also contact Toshiba by writing to:

Toshiba International Corporation
13131 West Little York Road
Houston, Texas 77041-9990
Attn: UPS Product Manager

For further information on Toshiba products and services, please visit our website at:

www.toshiba.com/ind

Table of Contents

General Safety Instructions	1
Symbols	1
Signal Words	2
Regulatory Compliance Statement	2
IMPORTANT SAFETY INSTRUCTIONS	3
QUALIFIED PERSONNEL ONLY	3
INSTRUCTIONS IMPORTANTES CONCERNANT LA SÉCURITÉ	4
Product Description	5
Application and Use	5
Output Rating.....	5
Power Backup.....	5
Power Conditioning.....	5
Inspection/Storage/Disposal	6
Inspection	6
Storage	6
Disposal	6
Installation Precautions	7
Conductor Routing and Grounding	9
Operating Precautions	9
Equipment Warning Labels	10
UPS Connections	13
Terminal Block	13
Wire Size and Tightening Torque.....	14
Communication Interfaces	16
UPS LAN Shutdown Signal Operation	17
RS-232C	18
RemotEye III Network Card	18
UPS Specifications	19
Operating the UPS	25
Initial Startup	25
Battery Backup Time and Discharge Process	26
Starting/Stopping the UPS.....	27
Battery Recharging	28
Operating Modes	29
On-Line (Run operation)	29
Static-Bypass (Stop operation)	29
Battery Backup (On batteries)	30

EPO (Emergency Power Off) Function.....	30
Audible Alarm Functions.....	31
Display and Keys	32
Front Panel Layout	32
Display Manual Controls.....	32
LCD Touchscreen Layout	33
Operating Keys	34
Status Indicators.....	35
Light Emitting Diodes (LED)	35
Touchscreen Menu Tree.....	36
Front Panel Layout	36
Screen Tab: Main.....	37
Keypad Controls	38
Screen: Security Passwords & Keypad	39
Screen Tab: Monitor	40
Screen Tab: Settings.....	42
Settings Parameters	46
Records	61
System Fault Messages	62
System Warning Messages	63
System Mode Messages	65
System Status Messages	65
UPS Protection System.....	67
System Protection Features	67
System Protection Functions	67
Preventive Maintenance/Parts Replacement	68
Preventive Maintenance	68
Cleaning the Touchscreen	68
Parts Replacement	69
Optional Receptacle Panel Installation Instructions.....	69
Optional MB (Maintenance Bypass) Units	71
Internal Maintenance Bypass	71
External Maintenance Bypass.....	72
External Layouts/Dimensions/Shipping Weights.....	73
Dimensional Data	73
Electrical Conduit Knock-out Data.....	73
Unit and Shipping Weights	73
Index	77

General Safety Instructions

DO NOT attempt to transport, install, operate, maintain or dispose of this equipment until you have read and understood all of the product safety information provided in this manual.

Symbols

The symbols listed below are used throughout this manual. When symbols are used in this manual they will include important safety information that must be carefully followed.



Safety Alert Symbol indicates that a potential personal injury hazard exists.



Prohibited Symbol indicates **DO NOT** take action.



Mandatory Symbol indicates that the following instruction is required.



Ground Symbol indicates the location of the equipment grounding conductor.



Electrical - Voltage & Shock Hazard Symbol indicates parts inside may cause electric shock.



Explosion Hazard Symbol indicates parts may explode.

Signal Words

The signal words listed below are used throughout this manual. When the words DANGER, WARNING, CAUTION and NOTICE are used in this manual they will include important safety information that must be carefully followed.



The word **DANGER** in capital letters preceded by the safety alert symbol indicates that an **imminently hazardous** situation exists, and if not avoided **will result in loss of life or serious injury to personnel.**



The word **WARNING** in capital letters preceded by the safety alert symbol indicates that a **potentially hazardous** situation exists, and if not avoided **may result in loss of life or serious injury to personnel.**



The word **CAUTION** in capital letters preceded by the safety alert symbol indicates that a **potentially hazardous** situation exists, and if not avoided **may result in minor or moderate injury.**



The word **NOTICE** in capital letters without the safety alert symbol indicates a **potentially hazardous** situation exists, and if not avoided **may result in equipment and property damage.**

Regulatory Compliance Statement

FCC Class A Notice

This equipment has been tested and found to comply with the limits for a Class A digital device, pursuant to Part 15 of the FCC Rules. These limits are designed to provide reasonable protection against harmful interference when the equipment is operated in a commercial environment. This equipment generates, uses, and can radiate radio frequency energy, and if it is not installed and used in accordance with the instruction manual, it may cause harmful interference to radio communications. Operation of this equipment in a residential area is likely to cause harmful interference, in which case the user will be required to correct the interference at his own expense.

This device complies with Part 15 of the FCC Rules. Operation is subject to the following two conditions:

1. This device may not cause harmful interference.
2. This device must accept any interference received, including interference that may cause undesired operation.

Notice: The FCC regulations provide that changes or modifications made to this device that are not approved by Toshiba International Corporation may void the authority granted to the user by the FCC to operate this equipment.

EMC Directive Class A Note

This UPS is commercial in design and not intended for use at anytime in a Residential Environment.

IMPORTANT SAFETY INSTRUCTIONS

This manual contains important instructions that should be followed during the installation and maintenance of the UPS and its batteries.

Hardwired UPS units are not equipped with an over-current protection device nor an output disconnect for the AC output. A circuit breaker should be provided by the user between the UPS output and the load input. This device should be rated as follows:

240VAC RATING	3.6 kVA	6 kVA	8 kVA	10 kVA	14 kVA	18 kVA	22 kVA
	20 A	35 A	45 A	60 A	80 A	100 A	125 A

The nominal battery voltages for these models are as follows:

BATTERY VOLTAGE	3.6 kVA	6 kVA	8 kVA	10 kVA	14 kVA	18 kVA	22 kVA
	144 Vdc	216 Vdc	288 Vdc	288 Vdc	288 Vdc	288 Vdc	288 Vdc

Servicing of the batteries should only be performed by a qualified factory authorized representative who is knowledgeable about batteries and the required precautions. Keep unauthorized personnel away from batteries. To arrange for battery replacement, contact your nearest factory authorized service center.

1. Turn off, lockout, and tagout all equipment before connecting the power wiring to the equipment or when performing maintenance.
2. Hardwired UPS units are not equipped with an over-current protection device, nor do they have an output disconnect for the AC output. Therefore, a user-installed circuit breaker should be provided between the UPS output and the load input.
3. The maximum ambient operating temperature is 104 °F (40 °C).
4. Access panels should only be removed by authorized Toshiba field Service personnel.
5. UPS servicing should be performed by qualified Toshiba representatives only.
6. Battery servicing should be performed by qualified Toshiba representatives only.
7. Contact your Toshiba authorized service center for battery replacement.

QUALIFIED PERSONNEL ONLY

Qualified personnel are those who have the skills and knowledge relating to the construction, installation, operation, and maintenance of the electrical equipment and have received safety training on the hazards involved (Refer to the latest edition of NFPA 70E for additional safety requirements).

Qualified personnel shall:

1. Have read the entire operation manual.
2. Be trained and authorized to safely energize, de-energize, ground, lockout and tag circuits and equipment, and clear faults in accordance with established safety practices.
3. Be trained in the proper care and use of protective equipment such as safety shoes, rubber gloves, hard hats, safety glasses, face shields, flash clothing, etc., in accordance with established safety practices.
4. Be trained in rendering first aid.
5. Be knowledgeable about batteries and their required handling and maintenance precautions.

For further information about workplace safety visit www.osha.gov.



Misuse of this equipment may result in human injury and equipment damage. In no event will Toshiba Corporation be responsible or liable for either indirect or consequential damage or injury that may result from the misuse of this equipment.



DO NOT dispose of the battery module in a fire. The batteries inside may explode.



DO NOT open or mutilate the batteries. Released electrolyte is harmful to the eyes and skin and could also be toxic.

To be performed by **Qualified Personnel Only**:

1. Verify that the UPS is off and that the power is disconnected from the power source.
2. Remove watches, rings or other metal objects.
3. Use tools with insulated handles to prevent inadvertent shorts.
4. Wear rubber safety gloves and boots.
5. DO NOT place tools or any metal parts on top of batteries.
6. Determine if the battery is inadvertently grounded. If inadvertently grounded, remove source of ground.

WARNING	
	<p>Contact with any part of a grounded battery can result in electrical shock.</p> <p>The likelihood of shock will be reduced if such grounds are removed prior to installation or maintenance.</p>

INSTRUCTIONS IMPORTANTES CONCERNANT LA SÉCURITÉ

CONSERVER CES INSTRUCTIONS

Cette notice contient des instructions importantes concernant la sécurité.



ATTENTION

Une battery peut présenter un risque de choc électrique, de brûlure par transfert d'énergie.



ATTENTION

L'élimination des batteries est règlementée. Consulter les codes locaux à cet effet.

Product Description

An uninterruptible power system (UPS) is a system that is installed between the commercial power and the load equipment. The UPS provides steady AC output power during commercial power short-term blackouts or brownouts. This power is provided for a long enough time so that the load can be shut down in an orderly fashion. This prevents loss of data and possible damage to both hardware and software.

During normal operation, the UPS uses commercial AC power. It absorbs all of the high voltage spikes and transients caused by switching and faults, and all of the common-mode and normal mode noise which is associated with commercial AC power. The UPS converts it all to flat DC power. From this power, the UPS charges its batteries and generates its own extremely high quality AC waveform output. The result of this process is maximum power conditioning and regulation.

If the AC power supplied to the UPS drops below a specified voltage level, the unit's batteries automatically begin supplying power instead of receiving it. This insures that the loads connected to the UPS continue to receive power with no interruption. When AC input power becomes available again, operation returns to normal. The unit's batteries begin to recharge so they will be ready for the next power interruption.

Application and Use

Toshiba 1600XP Series of On-Line UPS provides continuous computer-grade AC power in a compact, high performance, and energy efficient unit. The UPS unit assures safe and reliable operation of critical office equipment. All units feature an audible alarm which sounds if the battery voltage drops below a specified minimum during use. This is an additional aid to help protect valuable office data banks. All units allow for computer interfacing.

Output Rating

Toshiba 1600XP Series (208/240V) offers UPS models with the following capacities:

MODEL	Output Capacity @ 240 V	Output kW @ .85PF 240 V
UH3G2L036C61T	3.6 kVA	3.1 kW
UH3G2L060C61T	6 kVA	5.1 kW
UH3G2L080C61T	8 kVA	6.8 kW
UH3G2L100C61T	10 kVA	8.5 kW
UH3G2L140C61T	14 kVA	11.9 kW
UH3G2L180C61T	18 kVA	15.3 kW
UH3G2L220C61T*	22 kVA*	18.7 kW*

All models are RoHS compliant with the batteries being exempt from the directive.

*NOTE: Derate to 18.7 kVA (15.9 kW) for 50 Hz operation.

Power Backup

When an electrical power failure occurs, the UPS's internal batteries automatically supply back-up power to the load without interruption. For example, when used to support a computer, the UPS back-up assures enough additional time to complete the activity and store the data. This allows an orderly shutdown after a power failure has occurred.

Power Conditioning

When commercial power is present, the UPS supplies conditioned power to the load while maintaining its batteries in a charged condition. The UPS protects against the normal, everyday problems associated with heavy use of raw commercial power, including power sags, surges, signal interference, and spikes. This protection keeps power-line problems from reaching your load, where they can cause equipment to operate erratically, or damage software and hardware.

Inspection/Storage/Disposal

Inspection

Inspect for shipping damage upon receipt of the UPS. Use caution when removing the unit from the pallet. Refer to labels or documentation attached to packing material.

Unpacking

Check the unit for loose, broken, bent or otherwise damaged parts. If damage has occurred during shipping, keep all original crating and packing materials for return to the shipping agent. The warranty does not apply to damage incurred during shipping. Ensure that the rated capacity and the model number specified on the nameplate conform to the order specifications.

Storage

During periods of non-use, the following guidelines are recommended for storage.

Storage Preparation

1. Power up the UPS and allow it to operate with no load for 24 hours to fully charge the batteries.
2. Stop the unit (see Stop Operation on page 29).
3. Place the MCCB switch (see page 65-66 for location) in the Off position.

Storing Conditions

- For best results, store the UPS in the original shipping container and place on a wood or metal pallet.
- Storage temperature: -4 – 104 °F (-20 – 40 °C).
- The optimum storage temperature is 70 °F (21 °C). A higher ambient temperature will require recharging more frequently during storage.

Avoid storage locations that:

- Are subject to extreme temperature changes or high humidity.
- Are subject to high levels of dust or metal particles.
- Are subject to excessive vibration.
- Have inclined floor surfaces.

Storage Maintenance

- If stored at an ambient temperature less than 68 °F (20 °C), recharge the batteries every 9 months.
- If stored at an ambient temperature of 68 – 86 °F (20 – 30 °C), recharge the batteries every 6 months.
- If stored at an ambient temperature of 86 – 104 °F (30 – 40 °C), recharge the batteries every 3 months.

Disposal

Contact your local or state environmental agency for details on disposal of electrical components and packaging in your particular area.

It is illegal to dump lead-acid batteries in landfills or dispose of improperly.

Please help our Earth by contacting the environmental protection agencies in your area, the battery manufacturer, or call Toshiba toll-free at (877) 867-8773 for more information about recycling.

Installation Precautions

NOTICE

1. Observe the following environmental restrictions:
 - Install the unit in a well-ventilated location; allow at least 4 inches (10 cm) on all sides for air ventilation and for maintenance.
 - Install the unit where the ambient temperature is within the range specified on pages 20 and 23.
 - DO NOT install the UPS in areas that are subject to high humidity.
 - DO NOT install the UPS in areas that allow exposure to direct sunlight.
 - DO NOT install the UPS in areas that allow exposure to high levels of airborne dust, metal particles, or flammable gases.
 - DO NOT install the UPS in areas near sources of electrical noise. Ensuring a proper earth ground will reduce the effects of electrical noise and will reduce the potential for electrical shock.
 - DO NOT install the UPS in areas that would allow fluids or any foreign object to get inside the UPS.
2. UPS is intended for permanent installation only. Install the unit in a stable, level and upright position that is free of excessive vibration.
3. Allow at least 4 inches (100 mm) clearance on all sides of the ups for air ventilation.

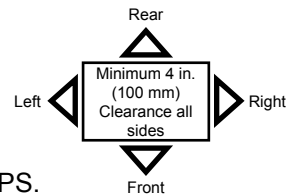

4. Follow the instructions on the unpacking label affixed to the exterior of the UPS.

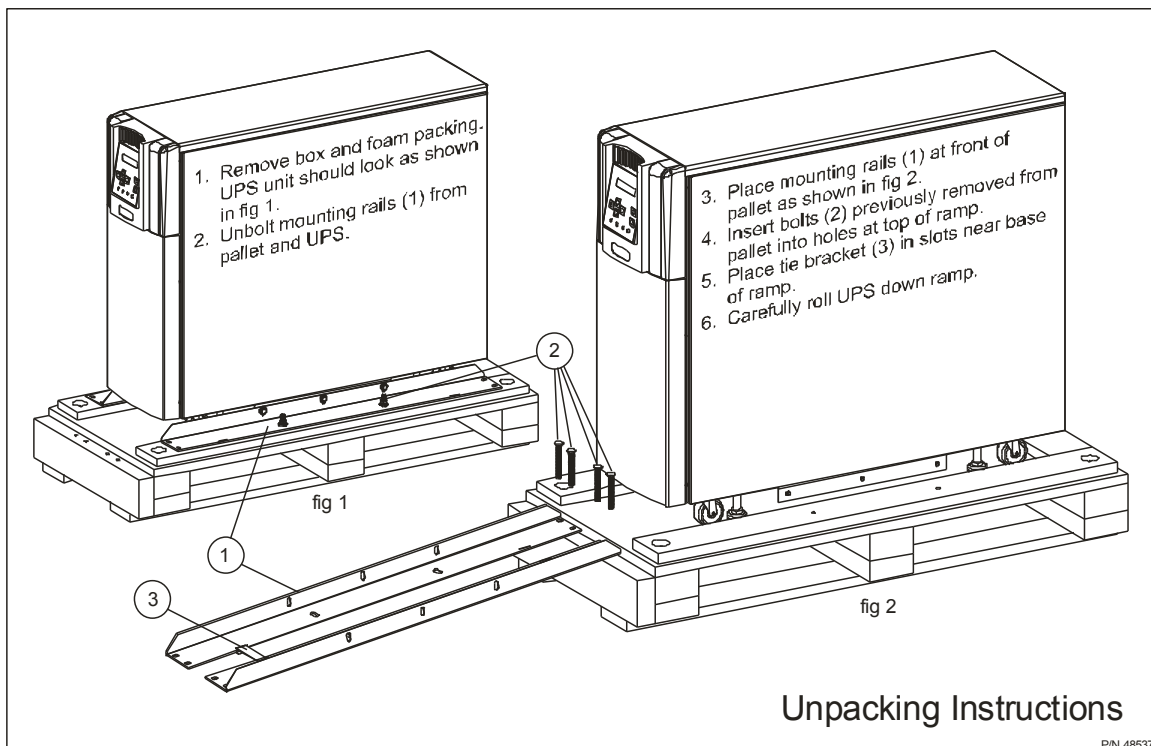

5. Once the installation is complete, use a 3/4 inch wrench to screw down the UPS leveling feet located next to the four casters, until the unit is no longer resting on the casters.
6. The UPS generates and can radiate radio-frequency energy during operation. Although RFI noise filters are installed inside of the unit, there is no guarantee that the UPS will not influence some sensitive devices that are operating near by. If such interference is experienced, the UPS should be installed farther away from the affected equipment and/or powered from a different source than that of the affected equipment.



7. It is the responsibility of the installer of this equipment to provide a suitable disconnect for the Control Panel supplying power to this equipment.

This disconnect must:

Be suitable for the Voltage and Full Load Ampere Rating of all downstream equipment supplied by the Panel;

The supply disconnecting device shall be one of the following types:

- Switch-disconnector, with or without fuses, in accordance with IEC 60947-3, utilization category AC-23B or DC-23B
- As above, except one that has an auxiliary contact that in all cases causes switching devices to break the load circuit before the opening of the main contacts of the disconnector.
- A circuit breaker suitable as an isolation device per IEC 60947-2
- Any other switching device in accordance with an IEC product standard that also meets the isolation requirements of IEC 60947-1 and is appropriate for on-load switching of motors or other inductive loads;

Be approved for use as a disconnect for the country in which this equipment is installed.

Be provided with a Lock Out Tag Out capability in the Off (Down) position.

8. Allow 5 minutes after power is removed for internal capacitors to fully discharge before attempting to service the unit.
9. The user should provide output over-current protection for hardwired UPS systems. See Specifications section on pages 19 and 22 for the device rating.
10. After ensuring that all power sources are turned off and isolated in accordance with established lockout/tagout procedures, connect the power source wiring of the correct voltage to the input terminals of the UPS.
11. The end user must supply suitable strain relief for the power cord and the cord must extend a distance of 1/2 diameter beyond the clamp.
12. Connect the output terminals of the UPS to the load in line with local wiring regulations. Size the branch circuit conductors in accordance with NEC Table 310.16.

Conductor Routing and Grounding

1. Use separate metal conduits for routing the input power, output power, and control circuits.
2. Follow the wire size and tightening torque specifications listed on page 14.
3. Always ground the unit to reduce the potential for electrical shock and to help reduce electrical noise.
4. A separate ground cable should be run inside the conduit with the input power, output power, and control circuits.



Operating Precautions

1. The UPS should not be powered up until the entire operation manual has been read.
2. The voltage of the input power source must be within the range of +10% to -30% of the rated input voltage. The input frequency must be within the rated input frequency range. Voltages and frequencies outside of the permissible range may activate the internal protection devices.
3. The UPS should not be used with a load that has a rated input that is greater than the rated output of the UPS.
4. DO NOT use the UPS to provide power to motors that require high starting current or with motors that require a long starting time, such as vacuum cleaners and machine tools (oversizing the UPS for lock rotor current would be required).
5. DO NOT insert metal objects or combustible materials in the ventilation slots of the UPS.
6. DO NOT place, hang, or paste any objects on the exterior surfaces of the UPS.
7. The capacitors of the UPS maintain a residual charge for a while after turning the UPS off. The required discharge time for each UPS typeform is provided via a cabinet label and a **CHARGE LED**. Wait for at least the minimum time indicated on the label and ensure that the **CHARGE LED** has gone out before opening the door of the UPS once the UPS power has been turned off.
8. DO NOT attempt to disassemble, modify, or repair the UPS. Repairs and servicing should only be performed by Toshiba Field Service personnel.
9. DO NOT remove any covers of the UPS when the power is on.
10. Turn the power on only after installing ALL of the covers.
11. If the UPS should emit smoke, produce an unusual odor, or make sound, turn the power off immediately.
12. The heat sink and other components may become extremely hot to the touch. Allow the unit to cool before touching these items.
13. Changing/replacing the UPS Batteries should only be performed by Toshiba field service personnel.

14. Warning signs should be placed on or near the load as a notification that the load is being powered by the UPS.
15. Additional warnings and notifications shall be posted at the equipment installation location as deemed required by **Qualified Personnel**.



When operating in the inverter mode, placing the breaker in the **OFF** position will switch the UPS to the battery backup mode. The output of the UPS will continue uninterrupted to the load. The unit must be in the bypass mode at the time that the breaker is placed in the **OFF** position for the UPS to shutdown power to the load.

Equipment Warning Labels

The following pages show examples of warning labels that may be attached to either the interior or exterior of the UPS. Do not remove or cover any of the labels. If the labels are damaged or if additional labels are required, contact your equipment representative for additional labels.

These labels are placed to provide useful information or to indicate an imminently hazardous situation that may result in severe equipment/property damage, serious injury, or loss of life if instructions are not followed.

Safety Label Explanations

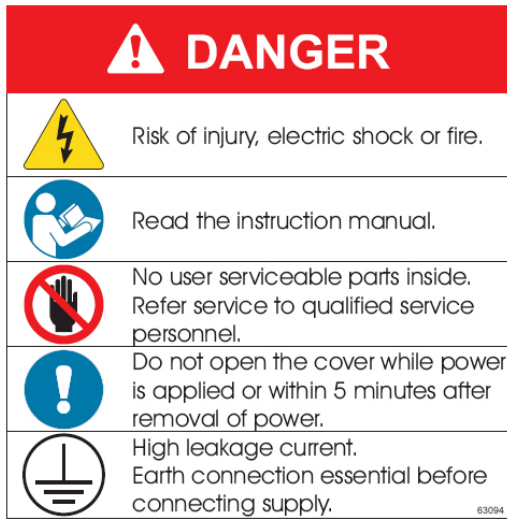

- P/N 63094 – External warning sign.
- Unit contains potentially dangerous voltages.
 - Read the instruction manual before operating.
 - There are no user serviceable parts inside. Refer service to qualified personnel.
 - Do not open the cover while power is applied, or within five minutes after removal of power.
 - Potentially hazardous leakage current may exist. Ensure the grounding is connected before connecting the utility power..

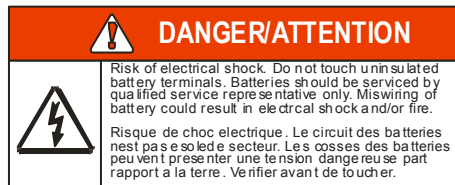

P/N 48518 – Battery terminals can deliver dangerous electrical shock. Service by qualified service representatives only.

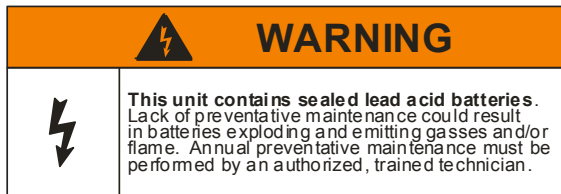

P/N 49455 – UPS Batteries require annual preventative maintenance. Failure to perform regular maintenance could result in batteries exploding, or emitting gasses or flame.

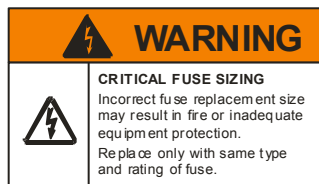

P/N 49455 – Replace Fuse only with one of same type and range. Incorrect fuse size may result in equipment damage.

WARNING

EXTERNAL BATTERY CABINET
The battery cabinet must have a nominal battery voltage of 288VDC.

PN 51727

P/N 51727 – External Battery Cabinet Connection, nominal Battery Cabinet Voltage of 288VDC required.

WARNING

Risk of electric shock. Do not remove cover. **NO USER SERVICEABLE PARTS INSIDE.** Refer servicing to qualified service personnel.

To reduce the risk of fire or electric shock, install in a temperature and humidity controlled indoor area free of conductive contaminants.

En cas utilisation en atmosphère contrôlée. Consulter la notice technique.

Note: Service personnel only.
Hazardous live parts inside the UPS are energized from the battery supply even when the input AC power is disconnected.

Capacitors store hazardous energy. Do not remove cover until 5 minutes after disconnecting all sources of supply.

Unit Rating (kVA)	3.6	6	8	10	14	18	22
Battery Type	VRLA						
Nominal Voltage (Vdc)	144	216	288	288	288	288	288
Nominal Capacity (Ah)	9						
Tray/Unit	2	3	4	4	8	8	8

Battery backup time, which was factory-set at a predetermined level, decreases gradually between service periods. The batteries should be replaced every three years after the last servicing, the date of which is written on the ID plate located on the rear side of the UPS unit or in the boxes below.

Date of last battery charge:

63109

P/N 63109 – There are no user-serviceable parts behind cover. Wait five minutes after disconnecting the UPS to allow the internal capacitors to discharge completely.

Date of last recorded battery change.

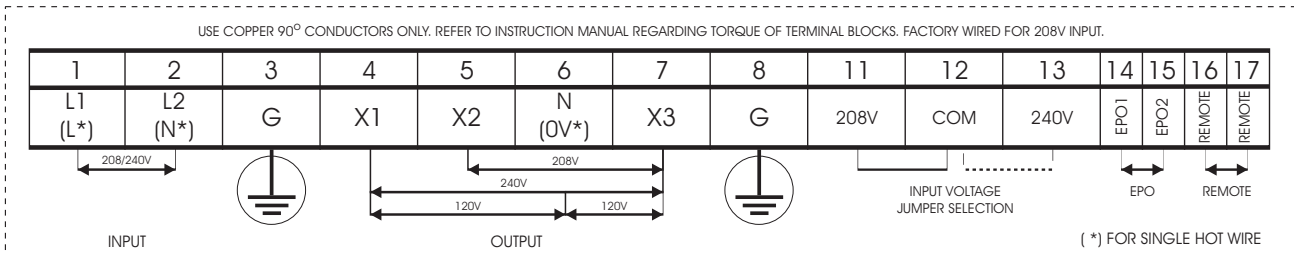

P/N63093 - Power Terminal Label

Wire Size and Tightening Torque

Use the following table to select the recommended wire size and terminal lug tightening torque for I/O wire connections. Use 90 °C copper conductors for all Input, Output, and Ground wiring.

Item	Terminal Number	Cable Size - AWG						Tightening Torque lb.-in. (N•m)
		3.6 kVA	6 kVA	8 kVA	10 kVA	14-18 kVA	22 kVA	
AC Input Lines	1 and 2	10 (8)	8 (8)	8 (1/0)	6 (1/0)	4 (1/0)	1 (1/0)	14.2 (1.56)
AC Output Lines	4, 5, and 7	12 (8)	10 (8)	8 (1/0)	6 (1/0)	4 (1/0)	1 (1/0)	14.2 (1.56)
AC Output Neutral	6	12 (8)	10 (8)	8 (1/0)	6 (1/0)	4 (1/0)	1 (1/0)	14.2 (1.56)
Ground	3 and 8	12 (8)	10 (8)	8 (1/0)	6 (1/0)	4 (1/0)	1 (1/0)	14.2 (1.56)
EPO Switch	14 and 15	16	16	16	16	16	16	9.0 (0.99)
Remote Switch	16 and 17	16	16	16	16	16	16	9.0 (0.99)

Note: Wire size is presented as the recommended size followed by a bold number in () that is the maximum wire size the terminal block can accommodate. See page 64 for knock-out hole sizes on the back of each model.

Optional Battery Cabinet Connections

Optional external battery cabinets can be used to extend the backup time of the UPS beyond that available with the internal batteries. The external battery cabinets connect to the UPS via Anderson-style connectors.

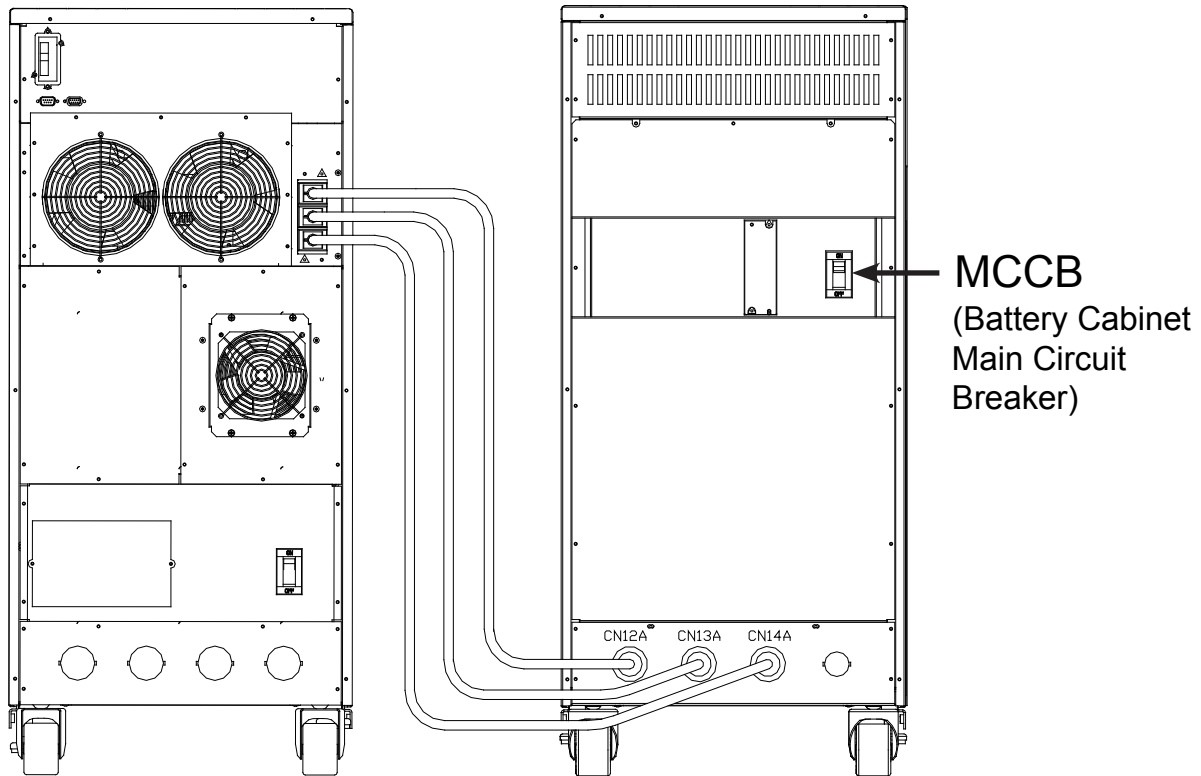

UPS Model	Battery Cabinet MCCB Capacity
3.6, 6 kVA	50 A
8, 10, 14, 18, 22 kVA	100 A

See the applicable battery cabinet manual for additional details.

Communication Interfaces

Remote Contacts

The remote contacts interface is provided as a set of solid state switching devices. The switches are available through a DB9 male connector on the rear of the UPS. The following chart shows the pin assignment for each signal.

MAXIMUM CURRENT CARRYING CAPACITY OF THE SWITCH

Voltage	Current
48 Vdc peak	70 mA peak
30 Vac rms (42 Vac peak)	50 mA rms (70 mA peak)

DB9 MALE CONNECTOR OUTLINE (FACING CONNECTOR)

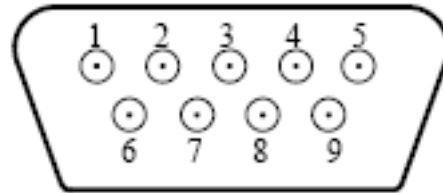

Pin	Signal Function	Logic	In the UPS
1	Fault Signal	Closed when fault detected	
2	UPS stop common	Backup stop when the level changes from Low (-3 to -15 V) to High (+3 to +15 V)	
3	UPS stop signal input		
4	Normal input power supply	Closed with normal supply power	
5	Signal common	Common signal return	
6	Bypass operation	Closed during bypass operation	
7	Battery voltage drop	Closed at voltage drop	
8	UPS operation	Closed during inverter operation	
9	Power failure signal	Closed at power failure	

NOTE: Pin switches are shown in their inactive states. For example, if battery voltage is low, pin 7 will be connected to pin 5.

UPS LAN Shutdown Signal Operation

When the UPS stop signal is sent to the UPS through pin 2 and 3 of the external contact interface, it is possible to automatically reset the following operating systems (OS), which can automatically implement the shutdown function and restart the operation: **Windows NT, IBM OS/2 LAN server, LANtastic**

Parameter 646 – UPS Shutdown by LAN Input Signal Enabled/Disabled

Parameter 647 – UPS Shutdown by LAN Signal Permitted Time Window (Adjustable)

With the **UPS Shutdown by LAN Signal** function enabled, when line power fails and the UPS goes to backup the LAN will shutdown even if the UPS returns to normal mode during the shutdown process.

LAN shutdown can take several minutes. The **UPS Shutdown by LAN Signal** function has a companion **UPS Shutdown by LAN Signal Permitted Time Window** parameter that can be set to allow sufficient time to complete the LAN shutdown process (default: 10 minutes) even if line power is restored during LAN shutdown.

LAN shutdown is treated as a restart after battery shutdown. The restart of the LAN will be determined by the **Restart After Battery Shutdown** timer.

Connect only the UPS stop signal to the external contact interface for automatic processing so that the UPS output will not be turned off by mistake.

If the computer is started/restarted within 10 minutes after the recovery from a power failure, the power supply may be reset while the computer is restarting.

RS-232C

The RS232C port can be used by authorized service personnel. The port is provided using a DB9 female connector located on the rear of the UPS. For reference, the pinout of the connector is illustrated below.

RS-232C CONNECTOR PIN ASSIGNMENT

Pin	I/O	Symbol	Description
1	This pin is not used		
2	Input	RXD	Receive data
3	Output	TXD	Transmit data
4	Output	DTR	Data terminal ready
5	-	SG	Signal ground
6	Input	DSR	Data set ready
7	Output	RTS	Request to send
8	Input	CTS	Clear to send
9	This pin is not used		

**DB9 FEMALE CONNECTOR OUTLINE
(FACING CONNECTOR)**

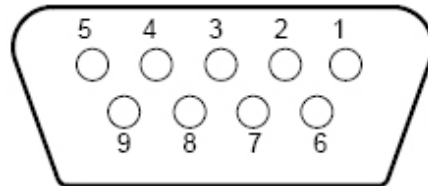

RemotEye III Network Card

The RemotEye III is an optional network card for the Toshiba UPS. This card slides into a slot located on the back side (page 65-66) of the UPS. The card provides a network, or LAN-based communication interface for the UPS. When installed, the UPS can be managed remotely using the common SNMP and HTTP web-based network protocols. The following diagram shows the flow of the Network Management Station.

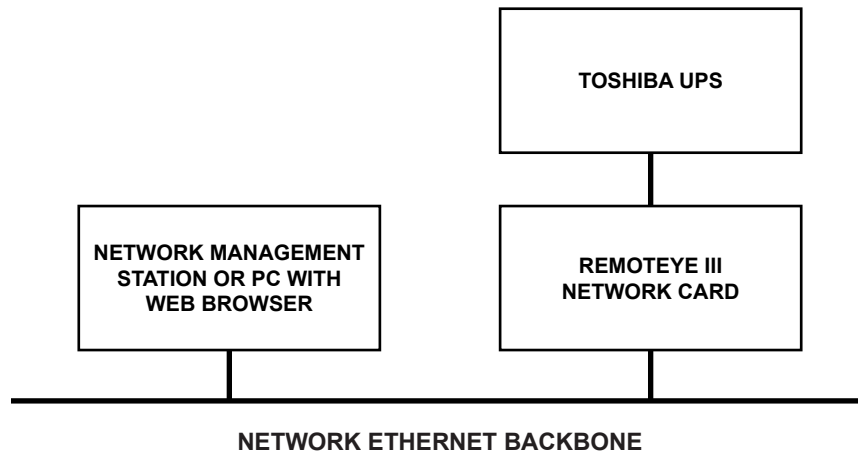

UPS Specifications

STANDARD MODEL: 3.6 – 10 KVA

Unit (Capacity)	3.6kVA (3.1 kW) ¹	6 kVA (5.1 kW) ¹	8 kVA (6.8 kW) ¹	10 kVA (8.5 kW) ¹
General				
Topology	True On-Line			
Certifications	ANSI C62.41 (IEEE 587), UL 1778, CUL, CE, FCC Class A , NEC (NFPS-70), NEMA/PE1-1993, OSHA, ASME, ISO 9001, ISO 14001:2004 , RoHS Compliant			
Input Characteristics				
Input Voltage ¹	Single-phase, 208/240 Vac, +10% to -30% ¹			
Input Frequency	45 – 65 Hz (auto-sensing)			
Input Capacity	3.6 kVA	6 kVA	8.0 kVA	10 kVA
Input/(Max Input) Current @208V	17.9 (18.7) A	29.8 (31.1) A	38.9 (40.5) A	48.6 (50.2) A
Input/(Max. Input) Current @240V	15.5 (16.2) A	25.9 (27.0) A	33.7 (35.1) A	42.1 (43.5) A
Input Power Factor	0.98 Typical, 0.95 Minimum@ 100% Load			
Current THD (linear load)	< 5% total harmonic distortion			
Internal AC Input Breaker Rating	30 A/277 V	50 A/277 V	60 A/277 V	63 A/277 V
Battery Characteristics				
Battery Type	Valve Regulated Lead Acid, Flame Retardant			
Backup time, fully charged @ 0.7 power factor, 77 °F	8 min. ²	8 min. ²	7 min. ²	7 min. ²
Backup time, fully charged @ 0.85 power factor, 77 °F	7 min. ²	7 min. ²	7 min. ²	5 min. ²
Recharge Time	24 hr. (full), 12 hr. (90%) for internal batteries only ³			
Battery Voltage (Nominal)	144 Vdc	216 Vdc	288 Vdc	
Output Characteristics				
Output Voltage	Single-phase, 240/208/120 V			
Output Voltage Regulation	= ± 3%			
Output Frequency	±0.5 Hz/1.0 Hz/1.5 Hz (factory or authorized service center selectable only)			
AUTO/MAN Frequency	Factory or authorized service center selectable only			
Voltage THD	< 3% for linear load; < 6% for non-linear load			
Common-Mode Noise	< 0.5 Vrms			
Rated Load Power Factor ¹	0.85 (0.6 – 1.0) lagging			
Efficiency (ac-dc-ac)	>83%		>85%	
Voltage Transient	< ±8% (Load of 0 – 100 %)			
Voltage Transient Recovery	50 ms to within 2% of nominal			
Rated Output Current (rms)	15 A	25 A	33.3 A	41.6 A
Max Peak Output Current	45 A	75 A	100 A	125 A
Inverter Overload Capacity	125% for 30 sec./150% for 10 sec.			
Bypass Overload Capacity	125% for 10 min./1000% for 1 cycle			
Crest Factor	3.0			

1. Input/output figures rated for 240 volts unless otherwise stated. Output ratings given for 0.85PF are only valid when the input voltage is greater than 204 volts; otherwise, ratings given for 0.70PF are applicable.
2. Battery backup time may vary depending on the operating conditions and ambient temperature at the installation site.
3. An initial charge time of 24 hrs. is necessary to obtain proper battery performance level before unit is placed in operation.

STANDARD MODELS: 3.6 – 10 KVA (CONT'D)

Unit (Capacity)	3.6kVA (3.1 kW) ¹	6 kVA (5.1 kW) ¹	8 kVA (6.8 kW) ¹	10 kVA (8.5 kW) ¹
Environment				
Operating Temperature 59 – 77 °F (15 – 25 °C) Recommended	60 Hz 32 – 104 °F (0 – 40 °C) 50 Hz 32 – 91 °F (0 – 33 °C)			
Storage Temperature	-4 – 104 °F (-20 – 40 °C)			
Installation Area	To be installed in a well ventilated area free of airborne dust, metal particles or flammable gas, allow at least 4 inches on all sides			
Operating Humidity	30 – 90% non-condensing			
Altitude	< 6600 ft. (2000 m) above sea level ²			
Acoustical Noise	50 dB (A) maximum @ 1 meter from front panel			
Heat Generation (Typical)	2139 BTU/Hr	3564 BTU/Hr	4095 BTU/Hr	5118 BTU/Hr
Operation Diagnosis				
Battery Check	Performed on start up, by schedule, on-demand (user configurable)			
Input OV Protection	Standard			
Battery Lifetime	UPS calculates battery replacement time based upon battery ambient temperature (LCD display, LED and beeps)			
Internal Temperature	UPS gives indication of internal temperature, alarm when high temp			
Event Data Storage	32 – Operation, 32 – Backup, 32 - Warnings, 32 – Faults, 32 - Test, 32 - System			
Applications				
Switches	Generator compatible			
Bypass Switch				
Bypass Disable	Static switch < ¼ cycle (50 Hz – 5 ms/60 Hz – 4.16 ms)			
Automatic Retransfer	Factory or authorized service center selectable only			
Interface/Communications				
Real Time Clock	Real Time Clock with backup Lithium Ion Battery			
Schedule Operation	Schedule ON/OFF operation of UPS using optional RemtoEye III communication software			
Autostart	Automatic UPS Startup when AC is applied - Option can be enabled or disabled at user's discretion			
Remote ON/OFF	Standard – External terminal			
Emergency Power Off	Standard – Terminal contacts only			
LED Display	3 LED's indicating On-Line/Fault, Warning, and A/C Input			
Operator Interface	Interactive Touchscreen			
Buzzer Volume	Standard (Fixed Volume)			
Power Connections	Standard – Hard wire, Optional – Receptacle Panel w/ Power Cord			
Remote Contacts	Standard (INV, BYP, BATT, LB, AC, FLT)			
RS232 ASCII Interface	Toshiba UPS Communication Protocol 2.0			

1. Input/output figures rated for 240 volts unless otherwise stated. Output ratings given for 0.85PF are only valid when the input voltage is greater than 204 volts; otherwise, ratings given for 0.70PF are applicable.
2. At 6600 ft (2000 m) above sea level, output capacity should be derated by 3%

STANDARD MODELS: 3.6 – 10 KVA (CONT'D)

Unit (Capacity)	3.6kVA (3.1 kW) ¹	6 kVA (5.1 kW) ¹	8 kVA (6.8 kW) ¹	10 kVA (8.5 kW) ¹
Mechanical Design				
Topology	Unit enclosure is made from sheet metal meeting NEMA1 and UL Type 1			
Size (HxWxD) (max)	22.1x 10 x 34 in. (561 x 254 x 864 mm)	27.5 x 10 x 34 in. (699 x 254 x 864 mm)	28.4x 13 x 34.9 in. (721 x 330 x 886 mm)	28.4x 13 x 34.9 in. (721 x 330 x 886 mm)
Paint System	Powder coating			
Fan Panel ²	Panel mounted on back of UPS to allow for easy replacement of fans			
Battery System				
Battery Replacement	Slide out battery packs accessible from front of UPS. Factory or authorized service center serviceable only.			
Battery Packs	Designed for battery acid leakage containment with six (6) batteries per pack			
Battery Pack Size (HxWxD) max.	5.0 x 7.3 x 19.0 in. (127 x 185 x 483 mm)			
Battery Pack Quantity	2	3	4	
Battery Manufacturer	YUASA			
Battery Type	REW45-12FR			
Toshiba's Part Number for Battery Pack	51896-FS			60995-FS

1. Input/output figures rated for 240 volts unless otherwise stated. Output ratings given for 0.85PF are only valid when the input voltage is greater than 204 volts; otherwise, ratings given for 0.70PF are applicable.
2. Remove all sources of main AC power and wait five minutes before replacing fans.

STANDARD MODELS: 14 – 22 KVA

Capacity	14 kVA (11.9 kW) ¹	18 kVA (15.3 kW) ¹	22 kVA (18.7 kW) ^{1, 5}
General			
Topology	True On-Line		
Certifications	ANSI C62.41 (IEEE 587), UL 1778, CUL, CE, FCC Class A , NEC (NFPS-70), NEMA/PE1-1993, OSHA, ASME, ISO 9001, ISO 14001:2004 , RoHS Compliant		
Input Characteristics			
Input Voltage ¹	Single-phase, 208/240 VAC, +10% to –30% ¹		
Input Frequency	45-65 Hz (auto-sensing)		
Input Capacity	14 kVA	18 kVA	22 kVA
Input I/(Max Input) Current @208V	67.2 (68.9) A	86.4 (88.1) A	106 (107) A
Input I/(Max Input) Current @240V	58.2 (59.7) A	74.9 (76.3) A	92.0 (93.0) A
Input Power Factor	0.98 Typical, 0.95 Minimum@ 100% Load ¹		
Current THD (linear load)	< 5%		
Internal AC Input Breaker rating	100 A / 277 V		125 A / 277 V
Battery Characteristics			
Battery Type	Valve Regulated Lead Acid, Flame Retardant		
Backup time, fully charged @ 0.7 power factor, 77 F	7 min. ²		5 min. ²
Backup time, fully charged @ 0.85 power factor, 77 F	7 min. ²	5 min. ²	3 min. ²
Recharge Time	24hr. (full), 12hr.(90%) for internal batteries only ³		
Battery Voltage (Nominal)	288 VDC		
Output Characteristics			
Output Voltage	Single-phase, 240/208/120 volts		
Output Voltage Regulation	= ±3%		
Output Frequency	±0.5Hz/1.0Hz/1.5Hz (factory/authorized service center selectable only)		
AUTO/MAN Frequency	Factory or authorized service center selectable only		
Voltage THD	< 3% for linear load; < 6% for non-linear load		
Common-Mode Noise	< .5 Vrms		
Rated Load Power Factor ¹	0.85 (0.6 - 1.0) lagging		
Efficiency (AC-DC-AC)	>86% ⁴		
Voltage Transient	< ±8% (Load of 0 to 100 %)		
Voltage Transient Recovery	50 ms to within 2% of nominal		
Rated Output Current (rms)	58 A	75 A	91.6 A
Max Peak Output Current	174 A	225 A	275 A
Inverter Overload Capacity	125%-30 sec./150%-10 sec		
Bypass Overload Capacity	125%-10 min./1000%-1 cycle		
Crest Factor	3.0		

1. Input/output figures rated for 240 volts unless otherwise stated. Output ratings given for 0.85PF are only valid when the input voltage is greater than 204 volts; otherwise, ratings given for 0.70PF are applicable.
2. Battery backup time may vary depending on the operating conditions and ambient temperature at the installation site.
3. An initial charge time of 24 hrs. is necessary to obtain proper battery performance level before unit is placed in operation.
4. Subject to update without notice.
5. Derate to 18.7 kVA (15.9 kW) for 50 Hz operation.

STANDARD MODELS: 14 – 22 KVA (CONT'D)

Capacity	14 kVA (11.9 kW) ¹	18 kVA (15.3 kW) ¹	22 kVA (18.7 kW) ^{1,4}
Environment			
Operating Temperature 59 – 77 °F (15 – 25 °C) Recommended	60 Hz 32 – 104 °F (0 – 40 °C) 50 Hz 32 – 91 °F (0 – 33 °C)		
Storage Temperature	-4 – 104 °F (-20 – 40 °C)		
Installation Area	To be installed in a well ventilated area free of airborne dust, metal particles or flammable gas, allow at least 4 inches on all sides		
Operating Humidity	30 – 90% (no condensation)		
Altitude	< 6600 ft. (2000 m) above sea level ²		
Acoustical Noise	50 dB (A) maximum @ 1 meter from front panel		
Heat Generation (Typical)	6610 BTU/Hr ³	8499 BTU/Hr ³	10,387 BTU/Hr ³
Operation Diagnosis			
Battery Check	Performed on start up, by schedule, on-demand (user configurable)		
Input OV Protection	Standard		
Battery Lifetime	UPS calculates battery replacement time based upon battery ambient temperature (LCD display, LED and beeps)		
Internal Temperature	UPS gives indication of internal temperature, alarm when high temp		
Event Data Storage	32 – Operation, 32 – Backup, 32 - Warnings, 32 – Faults, 32 - Test, 32 - System		
Applications			
Switches	Generator compatible		
Bypass Switch			
Bypass Disable	Static switch <1/4 cycle (50Hz: 5 ms/60Hz: 4.16 ms)		
Automatic Retransfer	Factory or authorized service center selectable only		
Interface/Communications			
Real Time clock	Real Time Clock with backup Lithium Ion Battery		
Schedule Operation	Schedule ON/OFF operation of UPS using optional RemotEye III communication software		
Autostart	Automatic UPS Startup when AC is applied - Option can be enabled or disabled at user's discretion		
Remote ON/OFF	Standard – External terminal		
LED Display	3 LED's indicating On-Line/Fault, Warning, and A/C Input		
Operator Interface	Interactive Touchscreen		
Buzzer Volume	Standard (Fixed Volume)		
Power Connections	Standard – Hard wire		
Emergency Power Off	Standard – Terminal contacts only		
Remote Contacts	Standard (INV, BYP, BATT, LB, AC, FLT)		
RS232 ASCII Interface	Toshiba UPS Communication Protocol 2.0		

1. Input/output figures rated for 240 volts unless otherwise stated. Output ratings given for 0.85PF are only valid when the input voltage is greater than 204 volts; otherwise, ratings given for 0.70PF are applicable.
2. At 6600 ft (2000 m) above sea level, output capacity should be derated by 3%
3. Subject to update without notice.
4. Derate to 18.7 kVA (15.9 kW) for 50 Hz operation.

STANDARD MODELS: 14 – 22 KVA (CONT'D)

Capacity	14 kVA (11.9 kW) ¹	18 kVA (15.3 kW) ¹	22 kVA (18.7 kW) ^{1, 2}
Mechanical Design			
Enclosure	Enclosure of unit made from sheet metal meeting NEMA1 and UL		
Size (HxWxD) (max)	39.0 x 17.5 x 36.1 in. (991 x 445 x 917 mm)		
Paint System	Powder coating		
Fan Panel	Panel mounted on back of UPS to allow for easy replacement of fans		
Battery System			
Battery Replacement	Slide out battery packs accessible from front of UPS, factory or authorized service center serviceable only		
Battery Packs	Designed for battery acid leakage containment with (6) batteries per pack		
Battery Pack Size (HxWxD) max.	5.0 x 7.3 x 19.0 in. (127 x 185 x 462 mm)		
Battery Pack Quantity	8		
Battery Manufacturer	YUASA		
Battery Type	REW45-12FR		
Toshiba Part Number for Battery Pack	51896-FS		60995-FS

1. Input/output figures rated for 240 volts unless otherwise stated. Output ratings given for 0.85PF are only valid when the input voltage is greater than 204 volts; otherwise, ratings given for 0.70PF are applicable.
2. Derate to 18.7 kVA (15.9 kW) for 50 Hz operation.

Operating the UPS

The 1600XP should be installed and adjusted by an operator. Once installed, the 1600XP is designed to be operated by laymen. Anyone not familiar with this UPS should read the manual before attempting to operate it.

Initial Startup (First Power-Up)

The first time the UPS is activated after being shipped from the factory, an initialization program will require the operator to input the following parameters. Input Rated Voltage, Output Rated Voltage, UPS Date, and UPS Time. The UPS display operation is explained in detail on pages 32-59.

The input frequency defaults to 60 Hz.

The first screen displayed during the initial startup sequence requires the operator to select the nominal Input Voltage. Select from 208V, 230V, or 240V, and press the **Write** key.

If the command has been accepted, the word "Successful" will appear at the bottom left side of the display.

1. Repeat the process in step 1 in selecting the Rated Output Voltage.
2. Use the keypad to type in the current date in the format: *Mon 10/05/2009*. and press **Write**.
3. Use the keypad to type in the current time in 12 hour format: *12:15 PM* and press **Write**.
4. The Main screen is now displayed. Verify the UPS is in BYPASS mode. The mode (lower right side of the display) should display **Bypass**. If it does not display **Bypass**, press and momentarily hold the **STOP** button on the Main display.
5. With the UPS in bypass mode, cycle power to the UPS as follows:
 - At the rear of the UPS switch the main circuit breaker MCCB to OFF.
 - Leave the UPS off until the DC bus is safely discharged (approximately 5-10 minutes).
 - Restart the UPS by switching the main circuit breaker ON.

The table below summarizes the initialization parameters:

ID	Command	Options
111	Rated Vin	Select from 208V, 230V, or 240V, and press Write .
215	Rated Vout	Select from 208V, 230V, or 240V, and press Write .
634	UPS Date	Input the date in this format: <i>Mon 10/05/2009</i> . and press Write .
635	UPS Time	Input the current time in 12 hour format: <i>12:15 PM</i> and press Write .

Battery Backup Time and Discharge Process

The UPS batteries provide approximately 5-7 minutes of back-up time depending on the 1600XP unit kVA rating. These times are valid when the unit is operating under full load and at the rated power factor. The exact length of these times will depend on the UPS model used, condition of the batteries, amount and type of load, temperature and other variables. See battery backup time in 'UPS Specifications' beginning on page 19.

The following illustration graphically shows the battery discharge process at full load conditions.

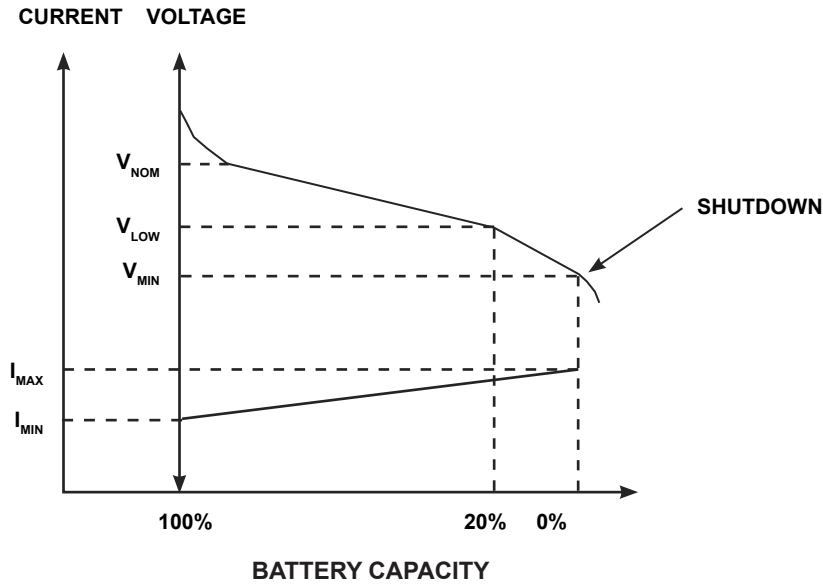

Battery Low Voltage Tolerances

Excessive discharge will cause the UPS battery voltage to drop. The chart shown below lists the voltage level at which each UPS low-voltage alarm will sound and at what level the low-voltage condition will cause the unit to automatically shut down.

UPS Capacity	3.6 kVA	6 kVA	8 kVA	10 kVA	14 kVA	18 kVA	22 kVA
Nominal voltage (Vnom)	144 Vdc	216 Vdc	288 Vdc	288 Vdc	288 Vdc	288 Vdc	288 Vdc
Alarm voltage (Vlow)	130 Vdc	192 Vdc	246 Vdc	246 Vdc	246 Vdc	246 Vdc	246 Vdc
Shutdown voltage (Vmin)	114 Vdc	170 Vdc	227 Vdc	227 Vdc	227 Vdc	227 Vdc	227 Vdc

Starting/Stopping the UPS

Turn the main circuit breaker (MCCB) on the back of the UPS (see pages 65-66) to the **ON** position. The breaker should normally remain in the **ON** position.

Verify that the **On-Line** LED on the front panel (see page 32) lights green. All LED's on the front panel may light for a moment when the input breaker is turned on. This is normal. The UPS will now be supplying power in the bypass mode.

NOTICE

When running the UPS for the first time or after the power failure backup operation, charge the batteries for at least 24 hours (input breaker on) before operating the connected load.

Using the UPS without charging the battery shortens the battery backup operation time, which may result in the destruction of data in case of a power failure.

Press **RUN** key to begin UPS operation (see page 37 for startup screens).

NOTICE

If the input breaker is turned off while UPS is in the bypass state, the output power stops. Any load devices will lose power.

Ensure that all sensitive loads have been previously shut down.

Stopping the UPS

To stop the UPS press and hold the **STOP** key approximately 1 second until the **On-Line** LED changes from green to off. The UPS is now in the bypass mode.

To completely stop the UPS, turn the input breaker at the back of the UPS to the **OFF** position.

Battery Recharging

The illustration below shows a graphical representation of the UPS battery recharge process after a full discharge.

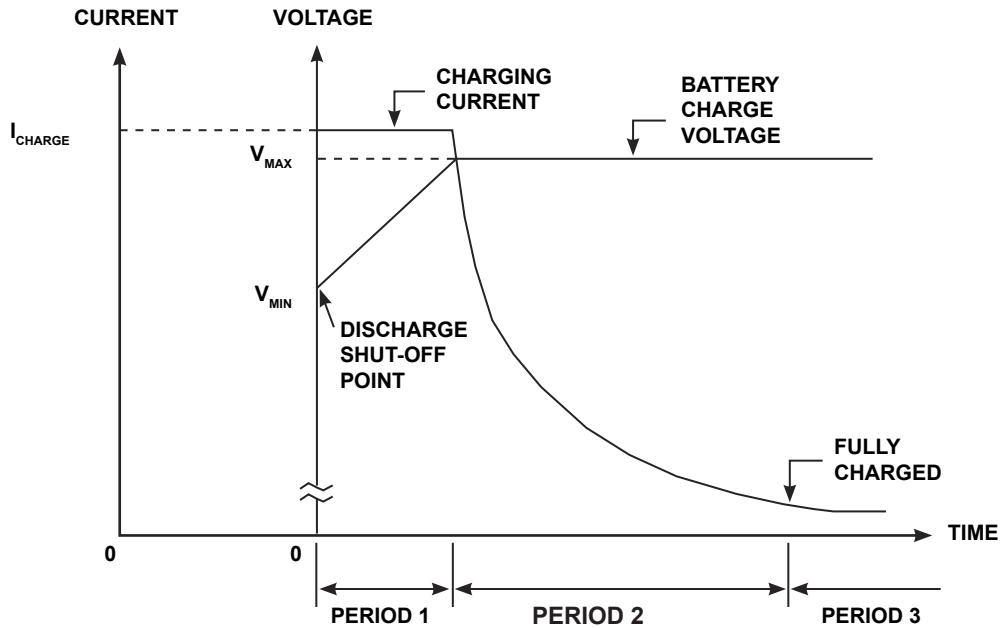

The recharge process usually consists of three periods. During the first period, the current is maintained at approximately 1 ampere. This current limit is the maximum value that can be used to charge the batteries (for minimal recharge time) while assuring safety and long battery life. In the second period, constant-voltage control starts and current gradually decreases as the batteries charge to their normal fully charged state. In the third period, a slight trickle current continues to flow into the batteries to keep them fully charged and floating at the normal Vdc level. A full recharge usually requires 24 hours (90% recharge in 12 hours) after a complete discharge.

The following chart shows the rated maximum and minimum battery voltages and the charge current for each of the sizes.

RATED BATTERY VOLTAGES

Model	Vmax	Vmin	Icharge
3.6 kVA	163 V	114 V	1.0 A
6 kVA	245.7 V	170 V	1.0 A
8 kVA	327 V	227 V	1.0 A
10 kVA	327 V	227 V	1.0 A
14 kVA	327 V	227 V	1.0 A
18 kVA	327 V	227 V	1.0 A
22 kVA	327 V	227 V	1.0 A

Operating Modes

On-Line (Run operation)

The following illustration shows circuit power flow when the UPS is operating normally in the On-Line mode. The UPS rectifier, including a boost chopper circuit, converts AC input power to DC power. The boost chopper circuit maintains a constant voltage, with current limiting, for charging the batteries. It also supplies a DC voltage of the proper level to the inverter section. The inverter section generates a high quality sinusoidal output voltage. The unit's batteries are always maintained in a constantly charged state when the UPS is in the run operation mode.

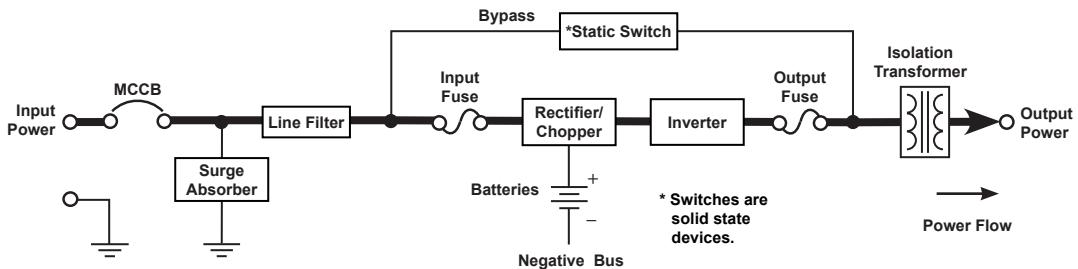

POWER FLOW IN ON-LINE MODE FOR ALL MODELS

Static-Bypass (Stop operation)

If the UPS unit is severely overloaded or develops an internal fault, power flow is automatically switched from the unit's main circuit to the bypass circuit. Power flow through the bypass is shown in the following illustration. This change-over occurs automatically in phase in less than one-quarter cycle of the input waveform. The switching period is not long enough to cause interruptions to occur in most loads.

- If the power flow is transferred to the bypass circuit because of an overload and that overload condition ends within a specified period of time then the power flow will be transferred back to the **On-Line mode** (run operation) automatically.
- If the power flow is transferred to the bypass circuit due to an external fault the UPS will shut down power through the bypass to the load and indicate a system fault message.
- If the power flow is transferred to the bypass circuit due to an internal fault the UPS will continue to supply power to the load through the bypass and indicate a system fault message (see system fault messages on pages 53–54).
- If the power flow is transferred to the bypass circuit due to an overload condition (see system warning messages on pages 54–55), then the power flow will automatically transfer from the UPS's bypass circuit back to the inverter circuit after removing the overload if set to do so (AutoReXfer parameter (Cmd ID 662)).

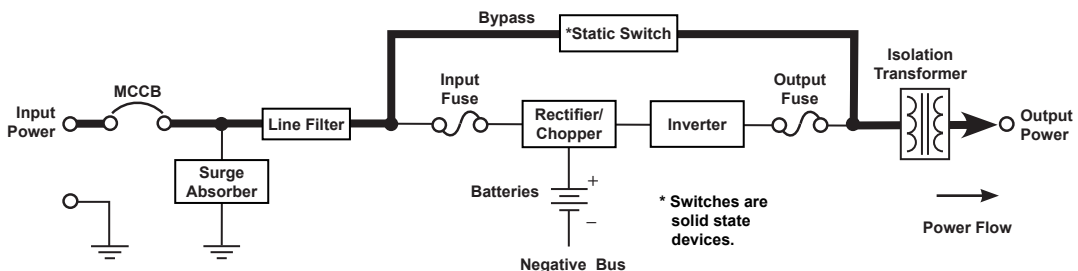

POWER FLOW IN BYPASS FOR ALL MODELS

Battery Backup (On batteries)

The following illustration shows power flow during the battery backup mode. When commercial AC power failures occur, the UPS's batteries instantly begin supplying DC voltage to the UPS's main inverter circuit. This circuit changes (inverts) the DC power into AC power. The AC power is available at the output of the unit.

This back-up process will continue until the UPS's battery voltage drops below a specific minimum level. When this occurs, the batteries will stop supplying power to the load. This minimum level is the rated minimum voltage (V_{min}). The rated battery voltage chart on page 28 shows (V_{min}). The battery backup time and discharge process is explained on page 28.

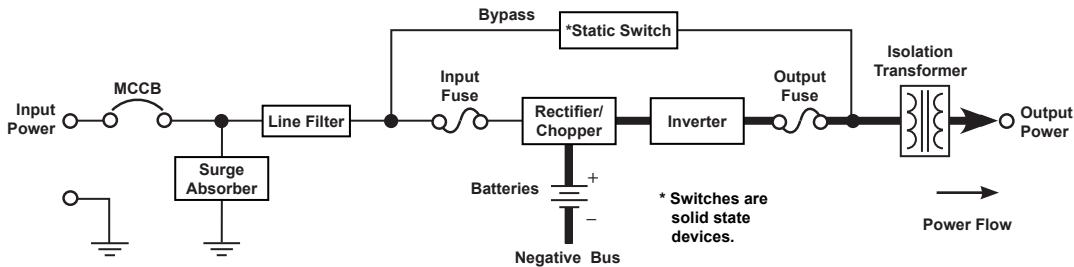

POWER FLOW IN BATTERY BACKUP FOR ALL MODELS

EPO (Emergency Power Off) Function

These units are equipped with terminals for receiving an emergency power-off (EPO) command via a closed-contact switch at a remote location (see Terminal Block Details on page 13 and terminal block location on pages 65-66). This safety feature enables quick shut-down of the UPS's AC output and battery circuits.

Usually the emergency power off switch is installed in a central location that is easily accessible to personnel concerned with the operation of the UPS unit and the load equipment connected to it. The EPO function is initiated by pressing the switch to the closed (shutdown) position.

The effect of using the EPO switch is the same whether the UPS unit is in AC input mode, battery backup mode, or the circuit bypass mode. The following figure shows the UPS condition after application of the EPO switch.

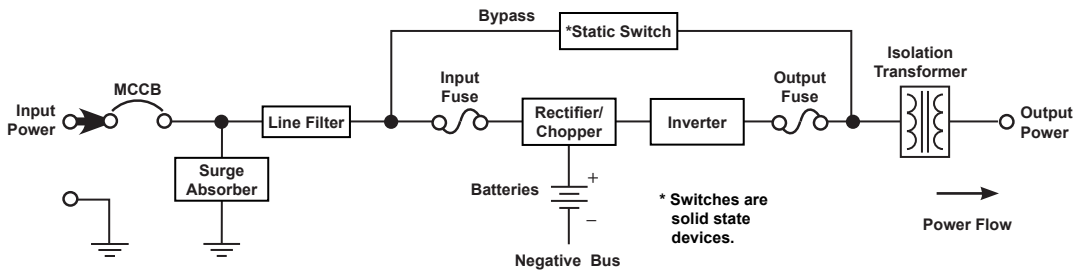





POWER FLOW AFTER AN EPO COMMAND FOR ALL MODELS

Audible Alarm Functions

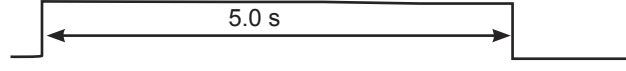
An audible alarm (buzzer) will sound when the UPS is in the battery backup mode, has a fault, has low battery voltage, or is in an overload condition. The buzzer will also beep each time an effective item is touched on the touchscreen. The following chart shows the buzzer pattern durations for each condition. Time units are shown in seconds.

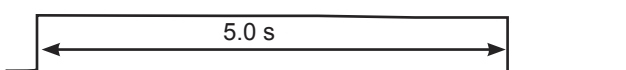
AUDIBLE ALARMS

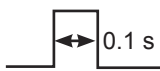
Condition	Audible Pattern
Any Fault (Intermittant buzz until fault clears)	
Switch to Backup (Single five-second buzz)	
Backup Operation (Intermittant buzz once every ten seconds)	
UPS Battery Shutdown Voltage (Batt. Voltage 79% Normal)	
Warnings: OL110 (Overload Timer) LB (Low Battery - Batt. Voltage 90% Normal) BLFN (Battery Life Pre-alarm - Batt exp in 6 mo.) BLFE (Battery Life End) CHRGV (Charger Over Voltage) BTSTFL (Battery Test Fail) BOH (Battery Overheat) AOH (Ambient Overheat) CLMT (Current Limit) DCER (Display Disconnected) BDEPL (Battery Depletion)	
Touching Effective Item on Touchscreen	

The buzzer can be silenced by selecting the Settings tab, then set the Mute Enable parameter to 1. This will turn off the buzzer for the current alarm status, but the buzzer will still sound when the next Fault/Warning condition occurs.

The buzzer can be disabled by selecting the Settings tab then setting the M buzzer parameter to 0. This will disable the alarm so that no alarm sounds for any Fault or Warning condition.

Display and Keys

Front Panel Layout

The front panel consists of several elements for monitoring and operation of the UPS. Panel components are shown in the illustration below:

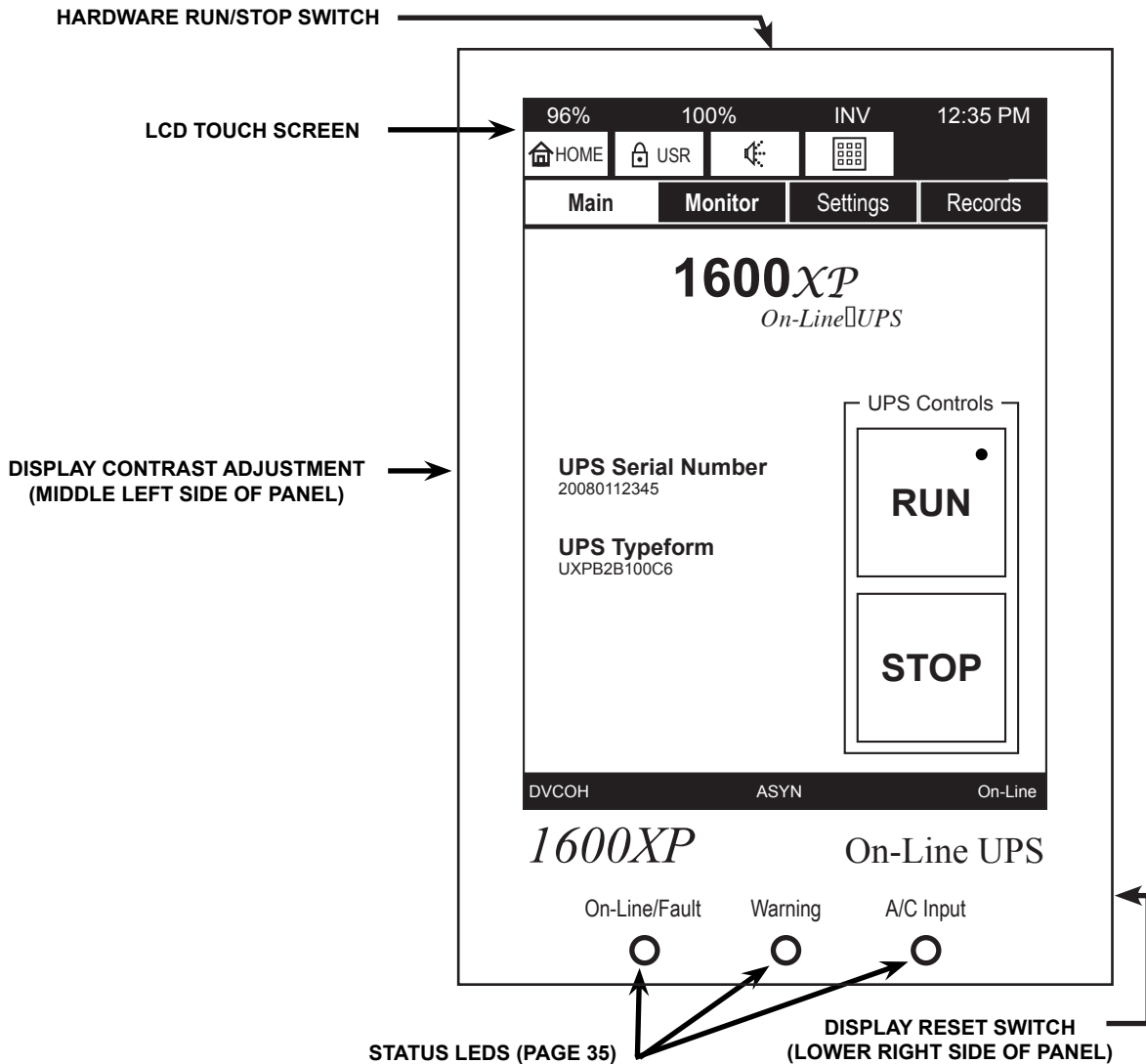

Display Manual Controls

Hardware Start/Stop Switch – Pressing the contact switch momentarily will toggle the UPS state between RUN and Bypass. For Instance, while the UPS is in RUN mode, pressing the switch will change the mode to Bypass. Pressing the switch again will switch the UPS back to RUN mode.

Display Reset Switch – When necessary, the touchscreen display can be reset by using a thin probe, such as a paper clip, to press the display reset switch.

Display Contrast Adjustment – The display is shipped with the display adjusted for optimum visibility. If necessary use a trimmer adjustment tool to fine tune the display contrast for improved visibility.

LCD Touchscreen Layout

The touchscreen serves as input and display. Touch the active portion of the display to execute a command.

Startup Display

The default opening screen for the UPS is the **Main** screen. The operator can begin operating the UPS immediately by pressing the RUN key.

Only the **Main** and **Settings** tab screens allow operator input. The **Monitor** and **Records** display screens are read-only. No data can be entered in these screens.

From the **Main** screen, the UPS can be placed On-Line by pressing RUN, or placed in Bypass Mode by pressing STOP.

The **Settings** screen allows modification of the UPS operating parameters.

At the top of the display are four status indicators: % Load, Battery Information, UPS System Status, and System Time.

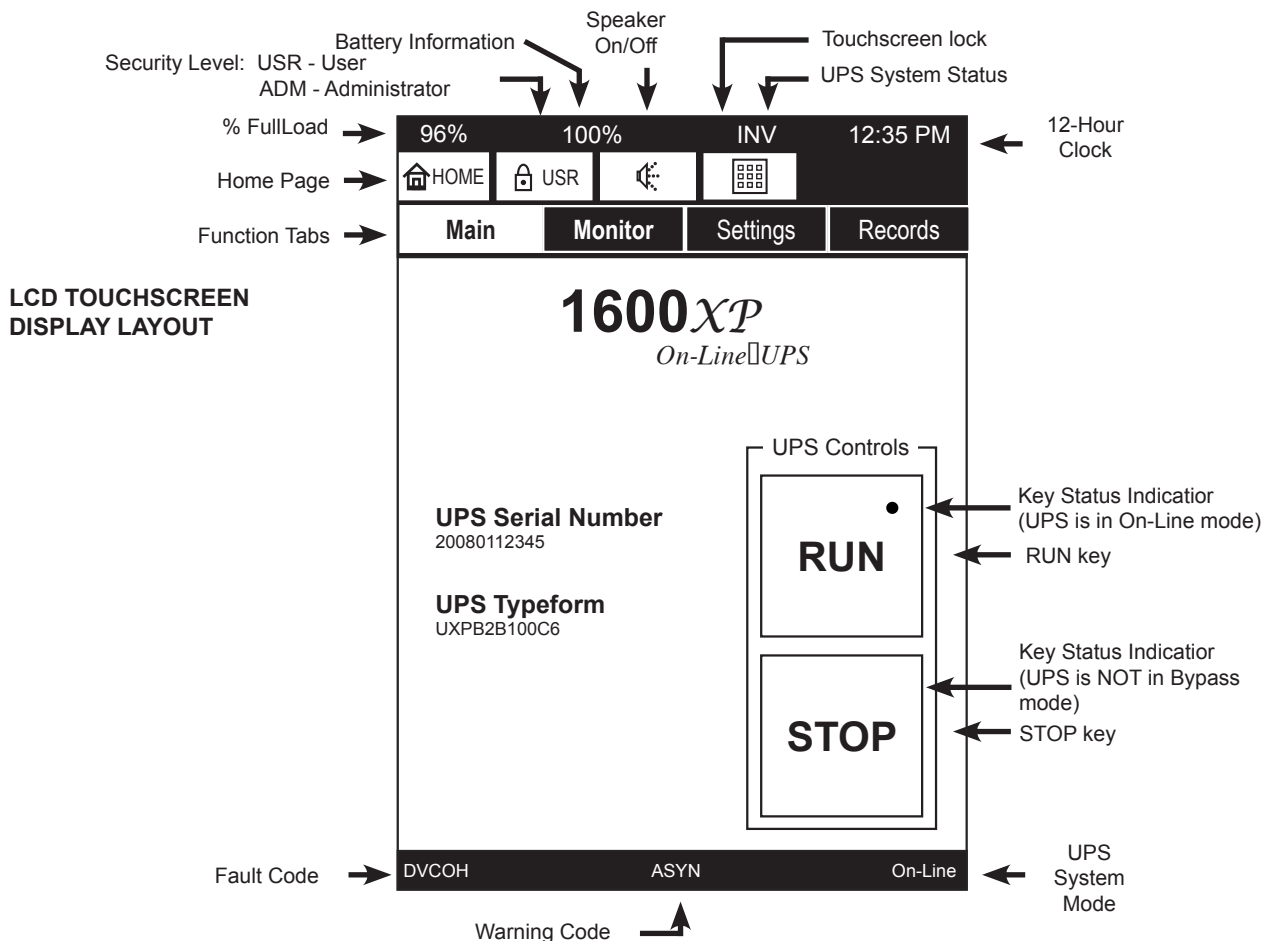

At the top left of the display are a bank of four touch-sensitive keys:

Home - Pressing **HOME** key returns the display to the top menu of the currently selected tab.

Security Level - Pressing the **Security Level** key activates the log-in security screen.

(Speaker) - Pressing the **Speaker** key will disable/enable the audible alarm.

Touchscreen Lock - Locks touchscreen except for this key.

The second row of keys are the function tabs.

At the bottom of the display three event codes display the latest operational information: Faults, Warnings, and the current UPS System Mode. (See pages 53–56.)

Operating Keys

The icons listed in the table below identify the touch-sensitive keys on the main touchscreen. The keys are different types of controls that can be activated by pressing that area of the touchscreen.

Key	Functional Description
	Run Key - Press and hold the key 1-2 seconds (until the UPS ‘beeps’) to put the UPS in On-line mode. The active status indicator (upper left hand dot) will appear on the RUN key and disappear from the STOP key..
	Stop Key - Press and hold the key 1-2 seconds (until the UPS ‘beeps’) to put the UPS in Bypass mode. The active status indicator (upper left hand dot) will appear on the STOP key and disappear from the RUN key.
	Home Key - Press to return to top menu of respective tab.
	Security Level Key. Press to open security login screen.
	Event Alarm Mute Key- Press to silence current event alarm.
	Alarm Muted Key- Alarm remains silenced until next event.
	Touchscreen Enabled Key- Press to disable (lockout) all touchscreen keys except this key.
	Touchscreen Disabled Key - Press to enable (un-lock) touchscreen.
	Four function tab keys: Main, Monitor, Settings, Records Main - Start and Stop keys, UPS Serial number and typeform. Monitor - Shows Mimic display for accessing Input/Output/Bypass/Battery data. Settings - Provides access to adjustable performance parameters. Records - Access fault, warning and other records.
	As displayed on: Monitor and Settings screens: Records screens: Go To First Page/Record Key. Go to Previous Page/Record Key. Menu selection under Monitor and Settings tabs. Shows the current page or record number, and total number of pages or records. Go to Next Page/Record Key. Go To Last Page/Record Key.



Status Indicators

The four top and three bottom UPS status Indicators on the main screen and their meanings are listed in the table below.

Indicator	Functional Description
96%	Shows the current load percentage.
100% / 11' 100% / 9' 35"	Battery Information: In On-line and Battery Back-up mode the display alternates between battery charge percentage and estimated remaining battery runtime in: Minutes for Runtimes > 10 min. Minutes and Seconds for Runtimes < 10 min.
100% / N/A	In other modes, the display alternates between battery charge percentage and "N/A."
INV	Shows current UPS Status. Indicator will change as the UPS status changes. For a detailed listing see page 56.
12:35 PM	System Time
DVCOH	Fault Description Code - For a detailed listing see 53.
ASYN	Warning Description Code - For a detailed listing see page 54.
On-Line	Current operating mode of the UPS - For a detailed listing see page 56.

Light Emitting Diodes (LED)

The following table describes the front panel LED behaviors and the associated meaning.

LED	Behavior	Significance/Meaning
 On-Line/ Fault	Green - ON	UPS is in On-Line, Backup, or Battery Test mode.
	Green - OFF	UPS in Bypass mode.
	Green - OFF	UPS in shutdown mode.
	Red - ON	One or more faults occurred. See <i>Records: Faults</i> for details.
	Red - Flashing	Charger overvoltage occurred.
	Red - OFF	No fault occurred.
 Warning	Amber - ON	Service Call needed, Less than 6 mo. of Battery Life or Battery Life End.
	Amber - Flashing	One or more Warnings occurred. See <i>Records: Warnings</i> for details.
	Amber - OFF	No Warning (Normal, UPS in operation).
 AC Input	Green - ON	Input and Bypass voltage is within specified range.
	Green - Flashing	Input and Bypass voltage is over specified range.
	Green - OFF	Input and Bypass voltage is under specified range.

NOTE: On-Line/Fault LEDs - Appear Orange if Green and Red flash concurrently.

Touchscreen Menu Tree

Front Panel Layout

The diagram below shows the menu tree for the touchscreen display. The four folder tabs and their associated sub-menu choices are shown on the left, and a description of the displays /choices are detailed on the right.

Tab: Main → ID/RUN-STOP

MAIN – Displays the starting screen. It has a **RUN** and **STOP** key that place the UPS in In-Line or Bypass mode respectively.

Tab: Monitor → Monitor Menu

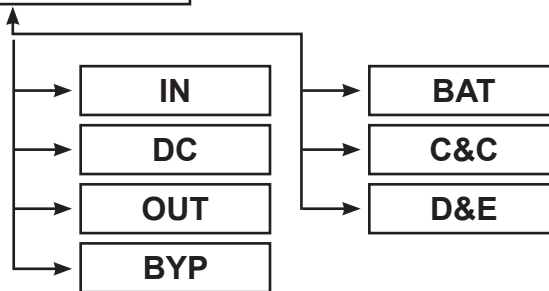

MONITOR – Graphically displays the current status of the UPS (On-Line, Backup, Bypass, Shutdown) in an interactive power flow block diagram. Selecting one of the blocks provides additional detailed data of the Input (**IN**), Output (**OUT**), Bypass (**BYP**), Battery (**BAT**), and DC Bus (**DC**), Control & Configuration (**C&C**), and Display & External (**D&E**) devices.

Tab: Settings → Settings Menu

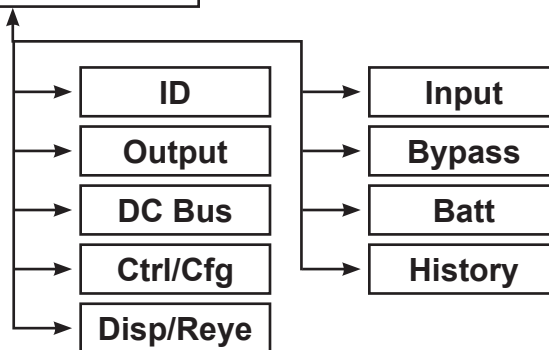

SETTINGS – Allows monitoring and/or modification of UPS parameters. Parameters that can be viewed or modified vary depending on the security level of the login password entered using keypad.

Tab: Records → Records Menu

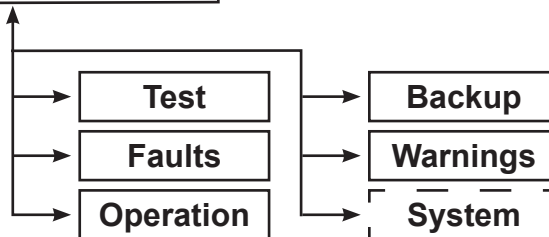

Records – Displays the most recent 32 **Test**, **Backup**, **Faults**, **Warning**, **Operation**, and **System** change records.

System records are only available at the distributor and depot security levels.

In any record set, if more than 32 incidences have occurred, only the most recent 32 record are retained in each report.

Screen Tab: Main

The Main tab is also the opening tab on startup for the UPS. Press **RUN** to place the UPS in On-Line mode, and press **STOP** to place the UPS in Bypass mode.

RUN/Stop the UPS

Press and momentarily hold (approximately one to two seconds) the **RUN** or **STOP** key to place the UPS in On-Line or Bypass mode respectively.

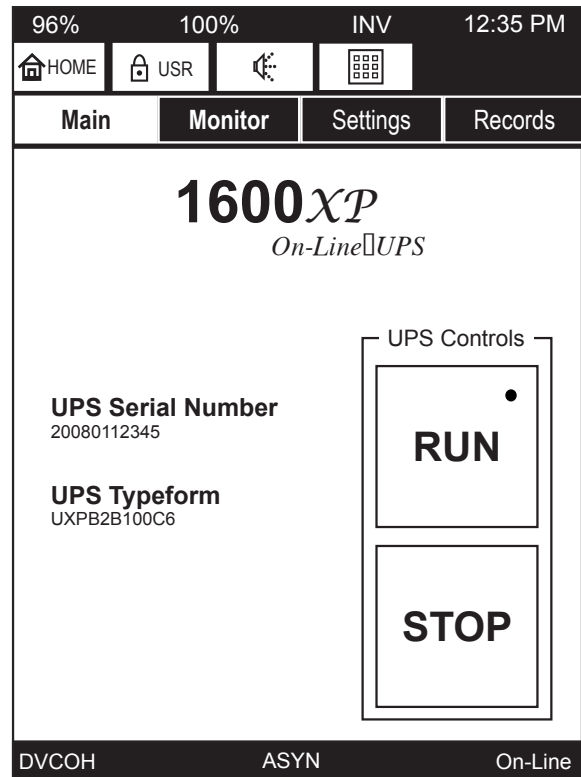

MAIN SCREEN

The touchscreen display can be disabled for safety or convenience by pressing the touchscreen lockout key, .

(NOTE: The touchscreen lockout key is disabled when the screen is in keypad mode.)

The Lockout key will change to  and the touchscreen will not respond to any input except a touch to the lockout key.

Touching the lockout key again will toggle the lockout off, the graphic will change to  indicating the touchscreen is active.

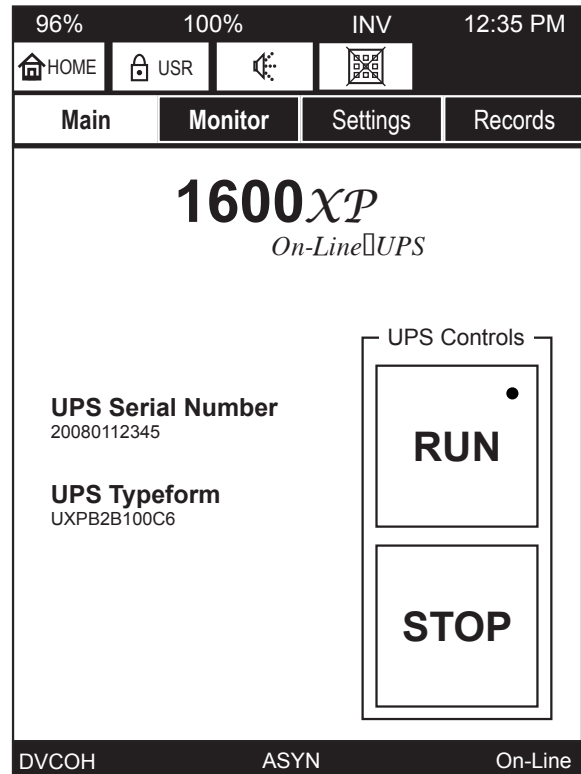

MAIN SCREEN DISABLED

Keypad Controls

The keypad uses an alphanumeric format similar to that used on telephone 12-key keypad. Rapidly press a key 1 to 5 times to select the desired character.

For instance, quickly press the **7PQRS** key four times to enter an “R.”

Pause a moment, then key in the next value.

Press the backspace key to delete the last character entered.

The keypad can be toggled to access to lower case letters and the space “ ” key by pressing the **Shift** key. Enter the lower case letters as above.

The Space key is used to enter a space between alphanumeric characters.

Example: By using the additional characters available with the shift key you can type in a device name:

“Toshiba H3” instead of “TOSHIBAH3”

Return to the Upper Case format keypad by pressing **Shift** again.

Exit the keypad display by pressing either the **Quit** or **Write** key.

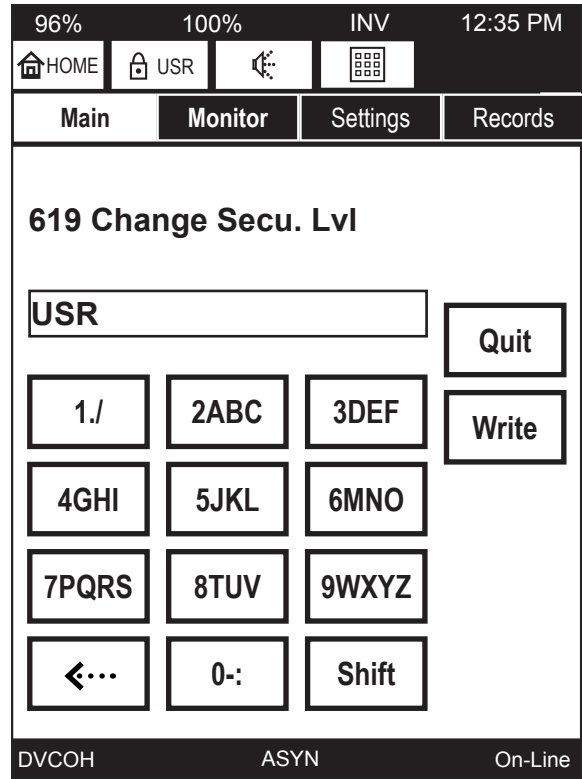

KEYPAD

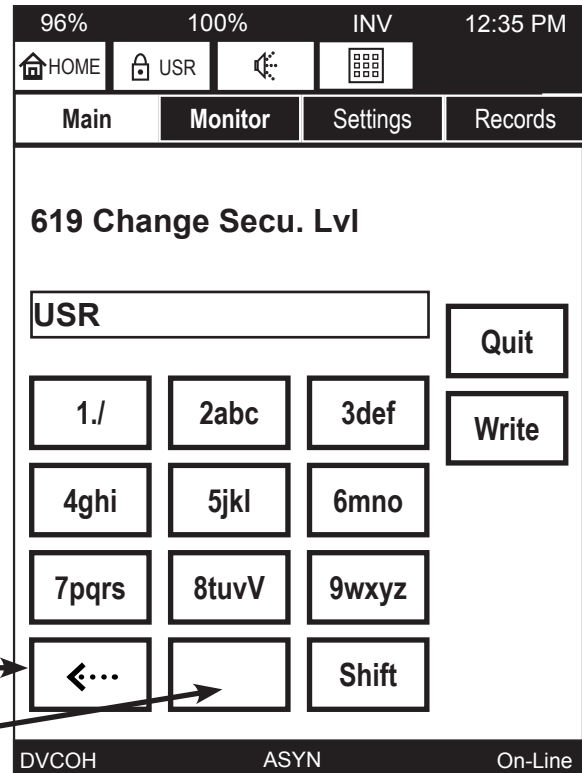

Backspace Key →
“Space” Key →

SHIFTED KEYPAD

Screen: Security Passwords & Keypad

The UPS has several levels of security password available: USER (USR) , ADMIN (ADM), and other security levels for use by service and factory representatives.

The security level is indicated on the Security Key.

The UPS stays in a security level until a new level is entered.

For example, once the UPS is placed in the USR level, it remains at that level until the security level is changed.

Login:

1. Press the **Security Level** key, .
2. The keypad replaces the Main screen to allow entering the password. By default the password are set to:
 User: USER
 Administrator: ADMIN
3. Typing in USER in the keypad will change the security level to User. Enter the password using the alphanumeric keys.
4. Press **Write** to store the password in the UPS. If the password is accepted the text “Successful” will display at the bottom left of the touchpad, as shown here.

If the password entered was not accepted, the text “Error15 – Write Function” or some similar message will indicate that the password or level change was not accepted.

5. Press the **QUIT** key and the keypad will close and the original display restored.

This same keypad is used for data input for parameters in the Settings tab.

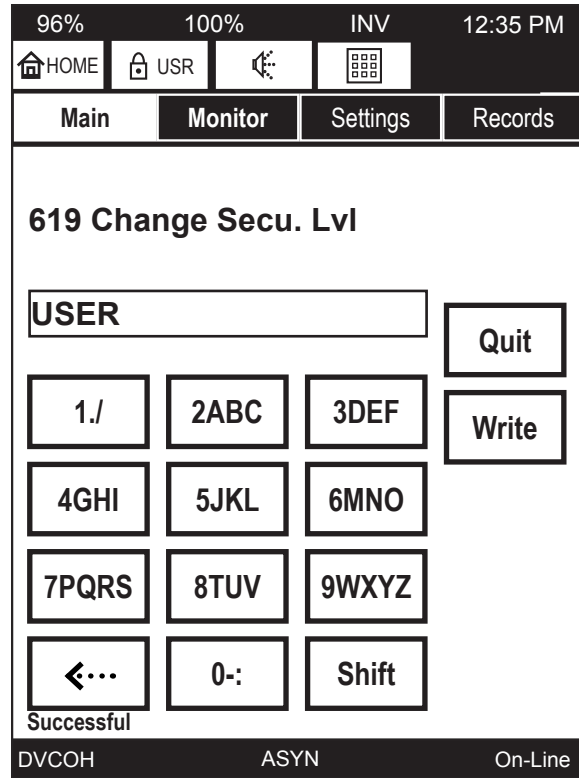

KEYPAD

Screen Tab: Monitor

The top screen under the Monitor tab is a graphical power flow block diagram that acts as a mimic display showing power flow through the UPS sections (Input, Output, Bypass, and Battery) and the UPS status (On-Line, Backup, Bypass, Shutdown). Additional information screens are available that display the detailed status of the various parameters for the Input, Output, Bypass, Battery, DC Bus, System Status, and Remote Communications.

The Monitor Tab illustration, next page, shows the screens available and how to navigate between them.

Mimic Display

In the mimic display of the Monitor Tab screen, the four UPS selection keys, Input (**IN**), DC Bus, (**DC**) Output (**OUT**), Bypass (**BYP**), and Battery (**BAT**) are connected by lines indicating power flow. A thick line indicates power flowing, and thin line indicates no power flowing.

The Monitor display, below, shows the UPS in Shutdown Mode: Power is flowing to charge the battery, but no power is going to the Bypass or Output.

Monitor Details

Press the **IN**, **BYP**, **OUT**, **DC**, or **BAT** key on the mimic display to view the parameter details for that section of the UPS.

The MONITOR TAB figure on the following page shows the relationship of the various data displays.

Press the Home key, , to return to the opening Monitor Tab screen.

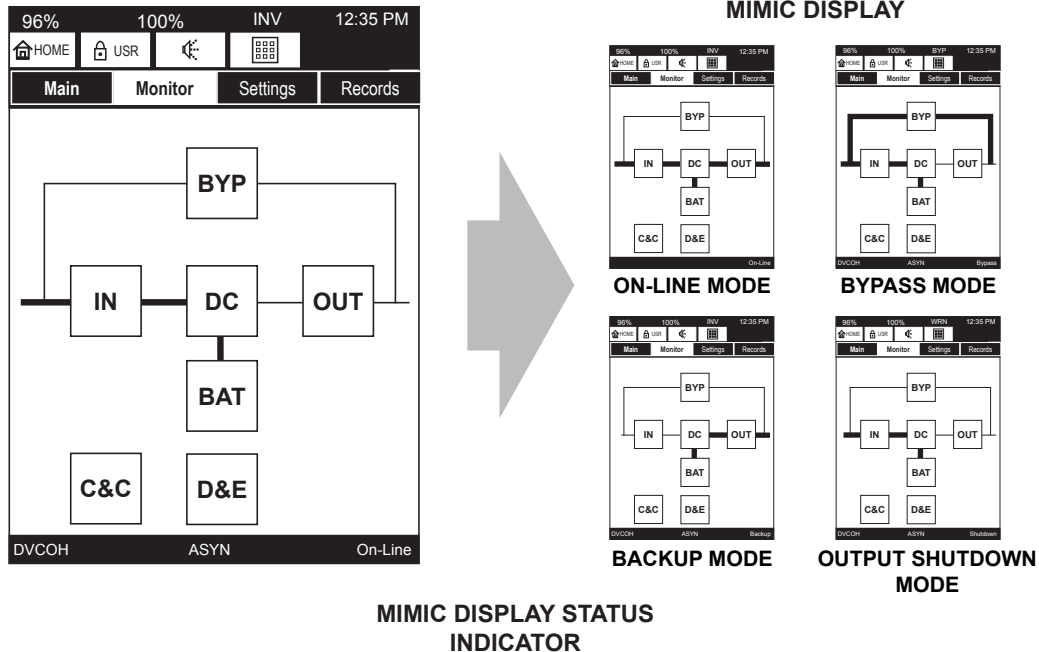

MONITOR TAB

MIMIC DISPLAY
Press any key on the mimic display (IN, DC, OUT, BYP, BAT, C&C, D&E) to display the associated parameters.

IN 1/3

101 Input Config	7
103 Input Voltage	238 V
104 Input Current	22.9 A
105 Input Frequency	60.0 Hz
106 Input Power (W)	5450 W
107 Input Power (VA)	5450 VA

DC 1/1

401 DC Bus Total	778 Vdc
402 DC Bus Positive	366 Vdc
403 DC Bus Negative	392 VdcA

BY 1/1

301 Bypass Config	7
303 Bypass Voltage	238 V
304 Bypass Current	0.0 A
305 Bypass Frequency	60.0 Hz
307 Bypass Power (VA)	0 VA

OUT 1/2

201 Output Config	7
203 Output Voltage	234 v
204 Output Current	21.4 A
205 Output Frequency	60.0 Hz
206 Output Power (W)	4590 W
207 Output Power (VA)	4986 VA

BAT 1/1

501 Battery Voltage	200 Vdc
503 Discharge Current	0.0 Adc
506 Charger Status	Normal
508 Cal Battery Vsd	172 Vdc
547 Cal LB Level	194 Vdc

C&C 1/2

601 System(CTL) Temp	25 C
602 Battery Temp	-15 C
608 Current State	Shutdown
611 EPO Status	Open
614 UPS Status (Comm)	00X00400060
615 RunStop SW Status	Stop

D&E 1/2

850 Reye Ins Dat	
851 Reye Ver	
852 Reye IP	
853 Reye Masik IP	
854 Reye Gway IP	
855 SReye	Not installed

Screen Tab: Settings

The tables on pages 47 – 51 list the 1600XP Settings parameters that can be viewed in the MONITOR tab.

Example: The Settings parameter **Batt Test Freq** (Battery Test Frequency) can be viewed by USR (User) level and above, only logged in ADM (Administrators) and above can edit the value.

Each key displays a block of relevant command parameters:

Key – (Cmd ID range) _____ Types of Parameters

- **ID** – (000-099) UPS specific information such as serial number, software versions, installation date.
- **Input** – (100-199) Input measured/calculated data such as input voltage, frequency, current, power, over-/under- voltage settings.
- **Output** – (200-299) Output measured/calculated data such as output voltage, frequency, current, power, over-/under- voltage settings.
- **Bypass** – (300-399) Bypass data such as configuration, voltage, current, power, OV detection level.
- **DC Bus** – (400-499) Data such as Total voltage, rated voltage, Positive and Negative bus voltages.
- **Batt** – (500-599) Battery voltage, charger status, total discharges, shutdown voltage.
- **Ctrl/Cfg** – (600-699) Control and configuration list system and battery temperatures, system status, startup delay, auto-transfer window, restart mode.
- **History** – (700-799) History lists metrics like system operation time, total over loads, hi system temp.
- **Disp/Reye** – (800-849) Display specific parameters like Disp. Firmware version, sleep timer, buzzer status, display calibration points, and RemotEye III settings.
(850-859) lists RemotEye III IP address, IP Mask, Status, Baud Rate, datalink status.

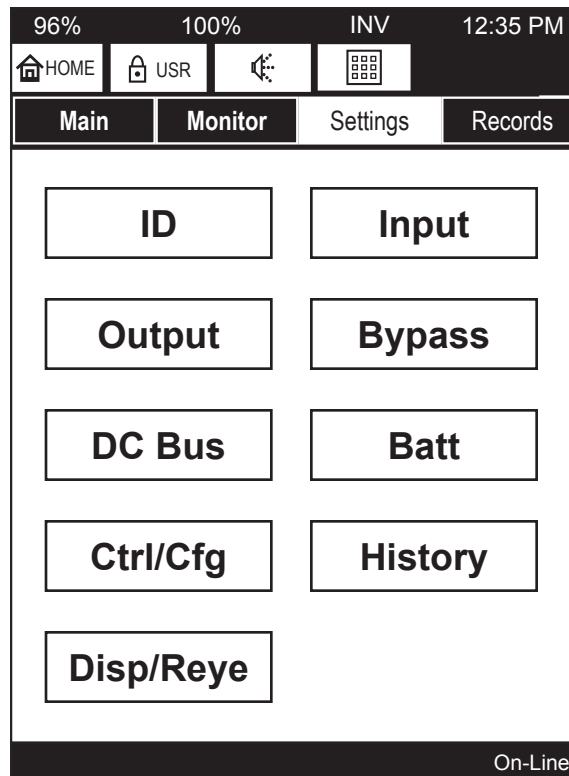

SETTINGS OPENING SCREEN

96% 100% INIT 12:35 PM	
HOME USR	
Main	Monitor
001 Manufacturer	TOSHIBA
002 Typeform	UH3G2L060C6
003 Serial No.	20080112345
004 Main FWare Ver	UH3MSV00013
005 Main BSector Ver	UH3MBS01000
006 Main BLoader Ver	UH3MBL01000
ID 1/3	
DVCOH	ASYN On-Line

ID BLOCK

96% 100% EPO 12:35 PM	
HOME USR	
Main	Monitor
102 No of Input Line	1 Line
111 Rated Vin*	240 V
119 VIOV DeLevel*	274 V
120 VIOV ReLevel*	264 V
141 Freq on FIERR*	50.0 Hz
IN 1/1	
DVCOH	ASYN On-Line

INPUT BLOCK

96% 100% FLT 12:35 PM	
HOME USR	
Main	Monitor
202 No of Output Line	1 Line
215 Rated Volt*	240 V
220 VOUV DeLevel*	90 %
222 VOOV DeLevel*	110 %
224 Fo Syn Window*	1.0 Hz
226 Vout Adjust	5 /128
OUT 1/1	
DVCOH	ASYN On-Line

OUTPUT BLOCK

96% 100% INIT 12:35 PM	
HOME USR	
Main	Monitor
302 No of Bypass Line	1 Line
315 VByUV DeLevel*	62 %
316 VByUV ReLevel*	66 %
317 VByOV DeLevel*	284 V
318 VByOV ReLevel*	274 V
BYP 1/1	
DVCOH	ASYN On-Line

BYPASS BLOCK

96% 100% FLT 12:35 PM	
HOME USR	
Main	Monitor
404 Rated DC Bus*	770 Vdc
DC 1/1	
DVCOH	ASYN On-Line

DC BUS BLOCK

96% 100% FLT 12:35 PM	
HOME USR	
Main	Monitor
507 Total Discharges	0
509 Batt Life Remain	4341 Hr
511 Rated Ahr*	9 Ahr
512 No Batt (Series)*	18
513 No Batt (Paral)*	1
514 Batt Install Date	8/24/2009
BAT 1/3	
DVCOH	ASYN On-Line

BATT BLOCK

96% 100% FLT 12:35 PM	
HOME USR	
Main	Monitor
609 Requested State	Idle
610 Timed Operation	0 Sec
612 Faults	0x00020000
613 Warnings	0x00000060
619 Change Secu. Lvl	USR
621 Reset Admin PWE	Idle
C&C 1/5	
DVCOH	ASYN On-Line

CTRL/CFG (SCC)BLOCK

96% 100% FLT 12:35 PM	
HOME USR	
Main	Monitor
701 System Op Time	07031 Sec
702 Inverter Op Time	0 Sec
703 Backup Op Time	0 Sec
704 UPS Lifetime	6118 Hr0
705 Hi System Temp	28 C
706 Hi Battery Temp	-8 C
HIS 1/4	
DVCOH	ASYN On-Line

HIST BLOCK

96% 100% FLT 12:35 PM	
HOME USR	
Main	Monitor
801 DFW Ver	UX3FV00000
802 DFW BDate	Feb 25 2009
803 DFW BTime	15:29:50
804 DBS Ver	UH3DBS01000
805 DBL Ver	UH3DBL01000
807 TMRsleep	10 Min
D&E 1/4	
DVCOH	ASYN On-Line

DISP/REYE BLOCK

Changing UPS Parameter Settings

Press the parameter to be changed and the display will open with an appropriate data entry screen. Settings that cannot be changed will respond with “Item cannot be changed” shown at the bottom of this page.

Some parameters will display one of a set of fixed values, such as example 1.

Example 1:

The UPS can have either one or two input lines. The value displayed in the Active Value box is the parameter in use. Alternate values are displayed in keys below the Active Value box.

After selecting the parameter value, press **Write** to write the entered value to the UPS memory and return to the original parameter screen.

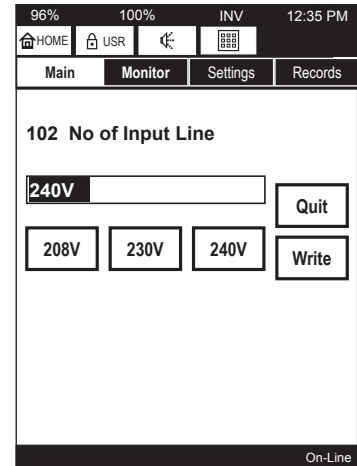

Some parameters can be any of a range of values, such as Rated Voltage In example 2.

Example 2:

The Rated Voltage In can vary over a range. Press the “Rated Vin” parameter listing and enter the correct value in the Active Value box. using the standard alphanumeric keypad.

Use the back arrow to delete an incorrect keystroke.

After changing the parameter value, press **Write** to write the entered value to the UPS memory.

Some parameters are informational, some can be changed by the user, and others can only be changed by a higher security access. If a parameter cannot be changed under the current security access level, selecting the parameter for change will generate the message “**Item cannot be changed**”.

Press **OK** to return to the original display.

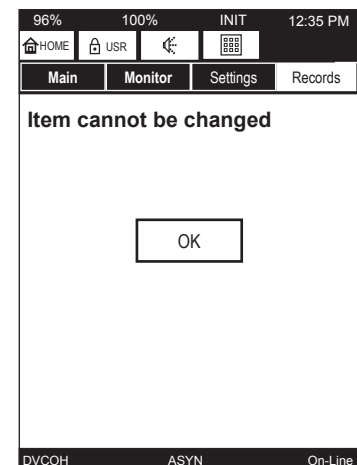
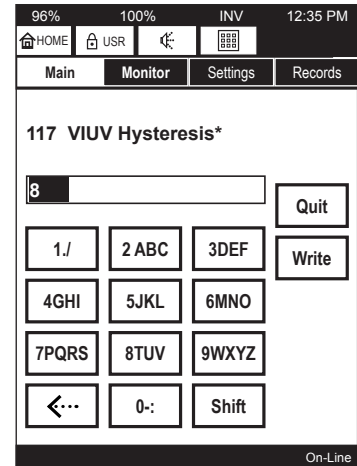

Recalibrate the Touchscreen

The touchscreen on the UPS is shipped from the factory already calibrated. However, at some point the touchscreen calibration may need to be refreshed so that the active portion of the screen matches the underlying graphics.

Recalibrate the Touchscreen as follows:

1. Press the **Settings** tab.
2. Press the **Disp/Reye** key.
3. Page forward to the second page and press the line:
810 Cali Display
4. The settings display will show the Cali Display screen.
5. Press the **Enable** key.
6. Press the **Write** key. (This will write the subsequent calibration values to the Control board.)
7. The display will switch to the CALIBRATION SCREEN shown below.
8. Gently press a stylus, or similar fine pointed tool, to the center of the X located at the top left-hand side of the display.
9. As soon as the information is read, a second X will be displayed at the top right-hand of the display. Repeat Step 7.
10. Repeat Step 7 for X displayed at the lower right-hand side of the display.
11. Repeat Step 7 for the X displayed at the lower left-hand side of the display.
12. After completing Step 10, the display will return to the *Cali Display* screen. Press the **Quit** key.

The touchscreen has been successfully recalibrated and the resulting values stored on the Control PCB.

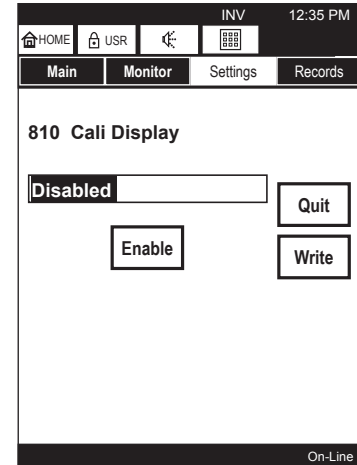

Cali Display SCREEN

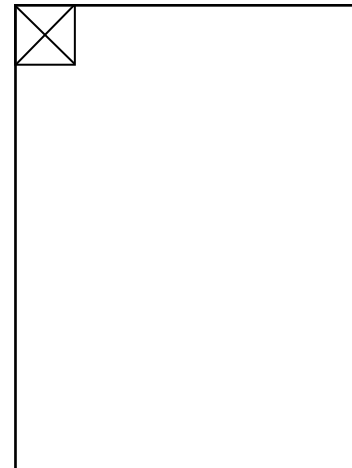

CALIBRATION SCREEN

Settings Parameters

The following table lists parameters parameters that can be viewed under the MONITOR tab of the touch-screen display.

The security levels are, from lowest to highest level:

<u>Access Level</u>	<u>Sec. Abbreviation</u>
User	USR
Administrator	ADM

The table headings are:

- **Cmd ID** - Command ID number. A three digit number between 000 and 999. Not all numbers have an associated parameter.
- **Description on LCD** - Display text, often abbreviated.
- **Brief Description** - Brief description of the function of the parameter.
- **Location Map - Tab/Blk** - Gives the menu location for the parameter by Tab and Block.
The tabs are Main, Monitor, Settings, Records.
E.g. Cmd 501 (Battery Voltage can be viewed under the Monitor tab, in the BATT block)
UPS Status is displayed in the display header Status field.
UPS Faults and Warnings are shown in the display footer, at the bottom of the display.
- **Example** - Shows an example of the parameter displayed on the touchscreen.
- **Rqd Security Level to Change/By** - The required security level to change a parameters value or setting: User, Administrator, Distributor.

1600XP Command Parameters Table									
Cmd ID	Description on LCD	Brief Description	Location Map		Example	Rqd Security Level to change	By		
			Tab	Block					
001	Manufacturer	UPS Manufacturer - Stores up to 16 characters.	Settings	ID	TOSHIBA	Nonchangeable Nonchangeable	User Administrator		
002	Typeform*	UPS Typeform	Settings	ID	UH3B2B060C6	Nonchangeable Nonchangeable	User Administrator		
003	Serial No.	UPS Serial Number	1. Main 2. Settings	ID	20080112345	Nonchangeable Nonchangeable	User Administrator		
004	Main FWare Ver	Main Firmware Version - The last 5 digit represents Main Controller's software version. In this example, the version is 1.000	Settings	ID	UH3MSW01000	Nonchangeable Nonchangeable	User Administrator		
005	Main BSector Ver	Main Bootsector Version - The last 5 digit represents Main Controller's Bootsector Version. In this example, the version is 1.000	Settings	ID	UH3MBS01000	Nonchangeable Nonchangeable	User Administrator		
006	Main BLoader Ver	Main Bootloader Version - The last 5 digit represents Main Controller's Bootloader software version. In this example, the version is 1.000	Settings	ID	UH3MBL01000	Nonchangeable Nonchangeable	User Administrator		
007	Job No.	Job Number - Toshiba's manufacturing job number.	Settings	ID	JB0123456789	Nonchangeable Nonchangeable	User Administrator		
008	Test Person	Test Person's First and Last Initial	Settings	ID	TA	Nonchangeable Nonchangeable	User Administrator		
009	Test Date	UPS Test Date at the Production - Format is YYYYMMDD	Settings	ID	20080101	Nonchangeable Nonchangeable	User Administrator		
010	HWare Built Date	Hardware Built Date - Format is YYYYMMDD	Settings	ID	20080101	Nonchangeable Nonchangeable	User Administrator		
013	Main EEPROM Ver	Main EEPROM Version	Settings	ID		Nonchangeable Nonchangeable	User Administrator		
015	System Name	System Name	Settings	ID	TOSHIBA H3, Control Plant	Nonchangeable Changeable	User Administrator		
016	Attached Device	UPS Attached Devices	Settings	ID	NONE	Nonchangeable Changeable	User Administrator		
017	Installed Date	UPS Installed Date at end user site	Settings	ID	20080101	Nonchangeable Changeable	User Administrator		

1600XP Command Parameters Table							
Cmd ID	Description on LCD	Brief Description	Location Map		Example	Rqd Security Level to change	By
			Tab	Block			
101	Input Config	Input Configuration which tell the voltage and frequency.	Monitor	IN	240V - 60Hz	Nonchangeable Nonchangeable	User Administrator
102	No of Input Line	No of Input Lines - Always 1 input line for 1600XP series	Setting	IN	1 Line	Nonchangeable Nonchangeable	User Administrator
103	Input Voltage	Input Voltage - UPS presently calculated input voltage	Monitor	IN	240 V	Nonchangeable Nonchangeable	User Administrator
104	Input Current	Input Current - UPS presently calculated input current	Monitor	IN	25.0 A	Nonchangeable Nonchangeable	User Administrator
105	Input Frequency	Input Frequency - UPS presently calculated input frequency	Monitor	IN	60.0 Hz	Nonchangeable Nonchangeable	User Administrator
106	Input Power(W)	Input Active Power - UPS presently calculated input active power. If UPS can not calculate for input apparent Power, display shows N/A.	Monitor	IN	5100 W	Nonchangeable Nonchangeable	User Administrator
107	Input Power(VA)	Input Apparent Power - UPS presently calculated input apparent power (input voltage * input current)	Monitor	IN	6000 VA	Nonchangeable Nonchangeable	User Administrator
108	Input PFactor	Input Power Factor - If converter is not running, display shows N/A.	Monitor	IN	1.0	Nonchangeable Nonchangeable	User Administrator
111	Rated Vin*	Rated Input Voltage - Used to calculate percentage and required to setup properly at very first time startup.	Setting	IN	240 V	Nonchangeable Changeable	User Administrator
112	Rated lin	Rated Input Current - Use this setup to calculate percentage.	Monitor	IN	25.0 A	Nonchangeable Nonchangeable	User Administrator
113	Rated Fin	Rated Input Frequency - Detected if auto detection and manual	Monitor	IN	60.0 Hz	Nonchangeable Nonchangeable	User Administrator
119	VIOV DeLevel	Input Overvoltage Detection Level - Of rated input voltage which was configured with Command ID 111.	Setting	IN	274 V	Nonchangeable Nonchangeable	User Administrator
120	VIOV ReLevel	Input Overvoltage Recovery Level - Of rated input voltage which was configured with Command ID 111.	Setting	IN	264 V	Nonchangeable Nonchangeable	User Administrator
135	Input Voltage(%)	Input Voltage Percentage	Monitor	IN	100 %	Nonchangeable Nonchangeable	User Administrator

1600XP Command Parameters Table							
Cmd ID	Description on LCD	Brief Description	Location Map		Example	Rqd Security Level to change	By
			Tab	Block			
136	Input Current(%)	Input Current Percentage	Monitor	IN	100 %	Nonchangeable Nonchangeable	User Administrator
137	VIUV DeLevel	Input Undervoltage Detection - Calculated according to load and adjusted by itself.	Monitor	IN	190 V	Nonchangeable Nonchangeable	User Administrator
138	VIUV ReLevel	Input Undervoltage Recovery - Calculated according to load and adjusted by itself.	Monitor	IN	200 V	Nonchangeable Nonchangeable	User Administrator
139	Rated InPower(W)	Rated Input Power in Watt - Calculated from typeform command ID 002.	Monitor	IN	6000 W	Nonchangeable Nonchangeable	User Administrator
141	Freq on FI-ERR*	Freq setup on input frequency error - Toshiba UPS try to detect input frequency but very tiny percentage when UPS can not detect the input frequency because of fluctuation, 1600XP UPS will start by using this setup.	Setting	IN	60.0 Hz	Nonchangeable Changeable	User Administrator
201	Output Config	Output Configuration - Displays the voltage and frequency 240 V 60 Hz, or 208 V 60 Hz	Monitor	OUT	240V - 60Hz	Nonchangeable Nonchangeable	User Administrator
202	No of Output Line	No of Output Lines - Always 1 input line for 1600XP series	Setting	OUT	1 Line	Nonchangeable Nonchangeable	User Administrator
203	Output Voltage	Output Voltage - UPS presently calculated output voltage	Monitor	OUT	240 V	Nonchangeable Nonchangeable	User Administrator
204	Output Current	Output Current - UPS presently calculated output current	Monitor	OUT	25.0 A	Nonchangeable Nonchangeable	User Administrator
205	Output Frequency	Output Frequency - UPS presently calculated output frequency	Monitor	OUT	60.0 Hz	Nonchangeable Nonchangeable	User Administrator
206	Output Power(W)	Output Active Power - UPS presently calculated output active power. If UPS can not calculate for output active power, display shows N/A. Especially, bypass and shutdown	Monitor	OUT	5100 W	Nonchangeable Nonchangeable	User Administrator
207	Output Power(VA)	Output Apparent Power - UPS presently calculated output apparent power.	Monitor	OUT	6000 VA	Nonchangeable Nonchangeable	User Administrator

1600XP Command Parameters Table							
Cmd ID	Description on LCD	Brief Description	Location Map		Example	Rqd Security Level to change	By
			Tab	Block			
209	Output Load (%)	Output Load Percentage - UPS presently calculated output load percentage	Monitor	OUT	100 %	Nonchangeable Nonchangeable	User Administrator
215	Rated Vout*	Rated Output Voltage - Must be setup properly at initial startup. Rated output voltage is used to calculate percentages for ID 220, 222	Setting	OUT	240 V	Nonchangeable Nonchangeable	User Administrator
216	Rated Iout	Rated Output Current - UPS calculated rated output current from typeform command id 002.	Monitor	OUT	25.0 A	Nonchangeable Nonchangeable	User Administrator
217	Rated Fout	Rated Output Frequency - UPS configures output frequency according to auto or manual mode,	Monitor	OUT	60.0 Hz	Nonchangeable Nonchangeable	User Administrator
218	Rated Pout(W)	Rated Output Active Power - Calculated from typeform command ID 002.	Monitor	OUT	5100 W	Nonchangeable Nonchangeable	User Administrator
219	Rated Pout(VA)	Rated Output Apparent Power - Calculated from typeform command ID 002.	Monitor	OUT	6000 VA	Nonchangeable Nonchangeable	User Administrator
220	VOUV De-Level*	Output Undervoltage Detection Level in Percentage - Of rated output voltage which was configured with Command ID 215.	Setting	OUT	90 %	Nonchangeable Nonchangeable	User Administrator
222	VOOV De-Level*	Output Overvoltage Detection Level in Percentage - Of rated output voltage which was configured with Command ID215	Setting	OUT	110 %	Nonchangeable Nonchangeable	User Administrator
224	Fo Syn Window*	Output Frequency Synchronization Window	Setting	OUT	1.0 Hz	Nonchangeable Nonchangeable	User Administrator
226	Vout Adjust	Output Voltage Adjustment - Can adjust up to +/- 5 increment of one in order to increase or decrease output voltage to compensate line voltage drop.	Setting	OUT	0	Nonchangeable Changeable	User Administrator
301	Bypass Config	Bypass Configuration - Which tell the voltage and frequency 240 V 60 Hz or 208 V 60 Hz	Monitor	BYP	240V - 60Hz	Nonchangeable Nonchangeable	User Administrator
302	No Of Bypass Line	No of Bypass Lines - Always 1 input line for 1600XP series	Setting	BYP	1 Line	Nonchangeable Nonchangeable	User Administrator

1600XP Command Parameters Table									
Cmd ID	Description on LCD	Brief Description	Location Map		Example	Rqd Security Level to change	By		
			Tab	Block					
303	Bypass Voltage	Bypass Voltage - Present calculated bypass voltage	Monitor	BYP	240 V	Nonchangeable Nonchangeable	User Administrator		
304	Bypass Current	Bypass Current - UPS presently calculated bypass current	Monitor	BYP	25.0 A	Nonchangeable Nonchangeable	User Administrator		
305	Bypass Frequency	Bypass Frequency - UPS presently calculated bypass frequency	Monitor	BYP	60.0 Hz	Nonchangeable Nonchangeable	User Administrator		
307	Bypass Power(VA)	Bypass Apparent Power - UPS presently calculated bypass apparent power.	Monitor	BYP	6000 VA	Nonchangeable Nonchangeable	User Administrator		
315	VByUV De-Level*	Bypass Undervoltage Detection Level - Percentage of rated input voltage command ID 111.	Setting	BYP	62 %	Nonchangeable Nonchangeable	User Administrator		
316	VByUV ReLevel*	Bypass Undervoltage Recovery Level in percentage - Of rated input voltage command ID 111.	Setting	BYP	66 %	Nonchangeable Nonchangeable	User Administrator		
317	VByOV De-Level	Bypass Over Voltage Detection Level in Volt	Setting	BYP	284 V	Nonchangeable Nonchangeable	User Administrator		
318	VByOV ReLevel	Bypass Over Voltage Recovery Level in Volt	Setting	BYP	274 V	Nonchangeable Nonchangeable	User Administrator		
401	DC Bus Total	DC Bus Voltage Total - Currently calculated DC Bus total voltage	Monitor	DC	770 Vdc	Nonchangeable Nonchangeable	User Administrator		
402	DC Bus Positive	DC Bus Voltage (+) - UPS presently calculated DC Bus positive voltage	Monitor	DC	385 Vdc	Nonchangeable Nonchangeable	User Administrator		
403	DC Bus Negative	DC Bus Voltage (-) - UPS presently calculated DC Bus negative voltage	Monitor	DC	385 Vdc	Nonchangeable Nonchangeable	User Administrator		
404	Rated DC Bus*	Rated DC Bus Voltage - Used to calculate percentage.	Setting	DC	770 Vdc	Nonchangeable Nonchangeable	User Administrator		
501	Battery Voltage	Charger or Battery Voltage - UPS calculates and shows current charger voltage during charging or battery voltage during Backup	Monitor	BATT	234 Vdc	Nonchangeable Nonchangeable	User Administrator		

1600XP Command Parameters Table									
Cmd ID	Description on LCD	Brief Description	Location Map		Example	Rqd Security Level to change	By		
			Tab	Block					
503	Discharge Current	Battery Discharge Current - UPS calculates and shows discharged current during Backup and 0.0 Vdc for others modes of UPS	Monitor	BATT	22.0 Vdc	Nonchangeable Nonchangeable	User Administrator		
506	Charger Status	Battery Charger Status - Shows charger's status which can be Normal, Preventive and Stop	Monitor	BATT	Normal	Nonchangeable Nonchangeable	User Administrator		
507	Total Discharges	Number of Battery Discharges - Increment count by one after UPS in Backup mode for 10 seconds	Settings	BATT	123	Nonchangeable Nonchangeable			
508	Cal Battery Vsd	Calculated Battery Shutdown Voltage - Calculated from the discharge rate during Backup mode	Monitor	BATT	172 Vdc	Nonchangeable Nonchangeable	User Administrator		
509	Batt Life Remain	Battery Lifetime Remaining	Settings	BATT	43800 Hr	Nonchangeable Nonchangeable	User Administrator		
511	Rated Ahr*	Rated Battery Ampere Hour - One of the battery's properties	Settings	BATT	9 Ahr	Nonchangeable Nonchangeable	User Administrator		
512	No Batt(Series)*	Number of Battery in Series	Settings	BATT	18	Nonchangeable Nonchangeable	User Administrator		
513	No Batt(Paral)*	Number of Battery in Parallel	Settings	BATT	1	Nonchangeable Nonchangeable	User Administrator		
514	Batt Ins Date	Battery installation Date - YYYY/MM/DD format	Settings	BATT	2008/01/01	Nonchangeable Nonchangeable	User Administrator		
516	Batt SDown Level*	Battery Shutdown Level - Percentage setting for shutdown level calculated. Actual shutdown level might be different depends on the rate of discharge	Settings	BATT	79 %	Nonchangeable Nonchangeable	User Administrator		
524	SbatEx	External Battery Status	Settings	BATT	Disable	Nonchangeable Nonchangeable	User Administrator		
525	Ex # Batt (Series)	Number of External Battery in Series	Settings	BATT	18	Nonchangeable Nonchangeable	User Administrator		
526	Ex # Batt (Parallel)	Number of External Battery in Parallel	Settings	BATT	1	Nonchangeable Nonchangeable	User Administrator		
527	Ex Batt Rated Ahr	External battery's Rated Ampere-Hour capacity	Settings	BATT	9 Ahr	Nonchangeable Nonchangeable	User Administrator		

1600XP Command Parameters Table									
Cmd ID	Description on LCD	Brief Description	Location Map		Example	Rqd Security Level to change	By		
			Tab	Block					
528	Ex Batt C Rate	External Battery C rate	Settings	BATT	0 C	Nonchangeable Nonchangeable	User Administrator		
529	Ex Batt Ins Date	External Battery Installation Date	Settings	BATT	01/01/2008	Nonchangeable Nonchangeable	User Administrator		
545	Low Batt Level*	Low Battery Level in Percentage - Percentage of nominal (# battery in series * 12 Vdc) will issue low battery warning during Backup	Settings	BATT	90 %	Nonchangeable Nonchangeable	User Administrator		
546	VChrgOV De-Delay	Battery Overvoltage Fault Detection Delay - Configurable between 0 to 300 Sec	Settings	BATT	60 Sec	Nonchangeable Nonchangeable	User Administrator		
547	Cal LB Level	Calculated Battery Shutdown Voltage - Calculated from the discharge rate during Backup mode	Monitor	BATT	194 Vdc	Nonchangeable Nonchangeable	User Administrator		
601	System(CTL) Temp	Ambient Temperature - Measured on control PCB	Monitor	C&C	26 C	Nonchangeable Nonchangeable	User Administrator		
602	Battery Temp	Battery Temperature - Measured on battery tray	Monitor	C&C	25 C	Nonchangeable Nonchangeable	User Administrator		
608	Current State	Current UPS State	Footer : Monitor	Right C&C	On-Line	Nonchangeable Nonchangeable	User Administrator		
609	Requested State	Requested UPS State	Main Settings	RUN/ STOP C&C	On-Line	Changeable Changeable	User Administrator		
610	Timed Operation	Timed Operation Request - Count down timer to switch UPS operations	Settings	C&C	On-Line	Changeable Changeable	User Administrator		
611	EPO Status	Emergency Power Off Status	Monitor	C&C	Open	Nonchangeable Nonchangeable	User Administrator		
612	Faults	UPS Faults - UPS Faults decoded at footer fault/s field or Setting Tab in hex format	Footer: Setting	Fault/s Field : C&C	DVCOH 0X00000008	Nonchangeable Nonchangeable	User Administrator		
613	Warnings	UPS Warnings - UPS Warnings decoded at footer warning/s field or Setting Tab in hex format	Footer: Setting	Warning/s Field : C&C	VIOV 0X00000001	Nonchangeable Nonchangeable	User Administrator		
615	Run/Stop SW Status	Run/Stop Switch Status	Monitor	C&C	Stop	Nonchangeable Nonchangeable	User Administrator		

1600XP Command Parameters Table									
Cmd ID	Description on LCD	Brief Description	Location Map		Example	Rqd Security Level to change	By		
			Tab	Block					
617	SPort Status	Service Port Status	Monitor	C&C	Unknown, Idle	Nonchangeable Nonchangeable	User Administrator		
618	Inter Comm Status	Internal Communication Status - Verifies communication occurring between display and main controller PCGs	Monitor	C&C	OK	Nonchangeable Nonchangeable	User Administrator		
619	Security Level	Security Level - Change the password with this command ID to have different level of security	Settings	C&C	USER, ADMIN	Changeable Changeable	User Administrator		
620	Manage Admin PW	Manage Admin Password - Default is ADMIN	Settings	C&C	ADMIN	Nonchangeable Changeable	User Administrator		
621	Reset Admin PW	Reset Admin Password - Restore administrator's password to default ADMIN	Settings	C&C	Idle	Changeable Changeable	User Administrator		
634	UPS Date	UPS Real Time Date (Battery Backup) - Follow the same format as display shows (Mon 10/05/2009)	Settings	C&C	Mon 10/05/2009	Changeable Changeable	User Administrator		
635	UPS Time	UPS Real Time (Battery Backup) - Use the same format as display shows (12 hour format)	Settings	C&C	11:46 AM	Changeable Changeable	User Administrator		
636	Timestamp	UPS Real Time Date and Time Stamp - Used for recording feature	Monitor	C&C	0X268AB487	Nonchangeable Nonchangeable	User Administrator		
637	En REye UPS Ctl	Enable REye UPS Control - Enable or disable RemoteEye Network Card to control UPS modes	Settings	C&C	Enable	Nonchangeable Changeable	User Administrator		
639	En Startup Delay*	Enable Startup Time Delay - Non-volatile configuration. Default from factory is Disable.	Settings	C&C	Disable	Nonchangeable Changeable	User Administrator		
640	Startup Mode*	Startup UPS Mode - Non-volatile configuration. Default from factory is Bypass. It can be changed to On-Line.	Settings	C&C	Bypass	Nonchangeable Changeable	User Administrator		
641	Startup Delay*	Startup Time Delay in Second - Non-volatile configuration. Default from factory is zero. You can configure up to 800 Seconds.	Settings	C&C	0 Sec	Nonchangeable Changeable	User Administrator		

1600XP Command Parameters Table									
Cmd ID	Description on LCD	Brief Description	Location Map		Example	Rqd Security Level to change	By		
			Tab	Block					
644	Remote SD Status	Status of Remote Shutdown Contact - If close, UPS go to shutdown mode if command id 645 is configured. If open after then it will go to previous ups mode	Settings	C&C	Open	Nonchangeable Changeable	User Administrator		
645	Mode of Rmt SDown	Mode of Remote Shutdown - Non-volatile configuration. When remote contact is close, it could go to bypass or shutdown.	Settings	C&C	Shutdown	Nonchangeable Changeable	User Administrator		
646	En DCntct LANSd	Enable Dry Contact LAN Shutdown - Non-volatile configuration. Default from factory is Enable.	Settings	C&C	Enable	Nonchangeable Changeable	User Administrator		
647	DCntct LANSd Wndw	Time Window of LAN Shutdown - Non-volatile configuration. Default from factory is 600 Seconds	Settings	C&C	600 Sec	Nonchangeable Changeable	User Administrator		
648	BK DContact Delay	Time Delay Remote Contact On Backup - Non-volatile configuration. Time delay for Backup dry contact will be on after UPS goes to Backup Mode. Default from factory is 10 Sec	Settings	C&C	10 Sec	Nonchangeable Changeable	User Administrator		
649	LB DContact Delay	Time Delay Remote Contact On Low Battery - Non-volatile configuration. Time delay for Low Battery dry contact will be on after UPS detects Low Battery warning. Default from factory is 0 Sec	Settings	C&C	0 Sec	Nonchangeable Changeable	User Administrator		
652	En Batt Test Sup*	Enable Battery Test at UPS Startup - Non-volatile configuration. Default from factory is Disable	Settings	C&C	Disable	Nonchangeable Changeable	User Administrator		
653	En Batt Test*	Enable or Disable Battery Test - Non-volatile configuration. Default from factory is Enable.	Settings	C&C	Enable	Nonchangeable Changeable	User Administrator		
654	Batt Test Cond	Battery Test condition status - Battery test can be performed if this command id is enable. It will set by UPS disable according to Command Battery test frequency.	Monitor	C&C	Enable	Nonchangeable Nonchangeable	User Administrator		
655	Batt Test Freq*	Max Battery Test Frequency - Non-volatile configuration. Default from factory is Monthly.	Settings	C&C	Monthly	Nonchangeable Changeable	User Administrator		

1600XP Command Parameters Table									
Cmd ID	Description on LCD	Brief Description	Location Map		Example	Rqd Security Level to change	By		
			Tab	Block					
658	En Restart	Enable Restart - Non-volatile configuration. After shutdown by battery, UPS will restart if input power recover. Default from factory is Enable.	Settings	C&C	Enable	Nonchangeable Changeable	User Administrator		
659	Restart Delay	Restart Delay	Settings	C&C	10 Sec	Nonchangeable Changeable	User Administrator		
660	En AutoXfer	Enable Auto Transfer - Non-volatile configuration. Enable auto transfer when current limit occurs. It will switch bypass and On-Line mode.	Settings	C&C	Enable	Nonchangeable Changeable	User Administrator		
662	AutoXfer Window	Auto Transfer Time Window - Non-volatile configuration. Default from factory is 3 Seconds.	Settings	C&C	3 Sec	Nonchangeable Changeable	User Administrator		
663	Srv Port Baud*	Service Port Baud Rate - Non-volatile configuration. Default from factory is 57600.	Settings	C&C	57600	Nonchangeable Changeable	User Administrator		
682	Special Purpose	(Call Factory for Further Information)	Settings	C&C		Nonchangeable Nonchangeable	User Administrator		
693	Invert Rmt SDown	Remoted Shutdown Inverted Logic - Non-volatile configuration. Default from factory is Normally Open	Settings	C&C	Normally Open	Nonchangeable Changeable	User Administrator		
695	Restart Mode*	Restart UPS Mode - Non-volatile configuration. Default from factory is On-Line	Settings	C&C	On-Line	Nonchangeable Changeable	User Administrator		
697	Special Purpose	(Call Factory for Further Information)	Settings	C&C		Nonchangeable Nonchangeable	User Administrator		
701	System Op Time	Total System Operation Time - Non-volatile history record. Default from factory is zero.	Settings	HIST	123 Sec	Nonchangeable Nonchangeable	User Administrator		
702	Inverter Op Time	Total Inverter Operation Time - Non-volatile history record. Default from factory is zero.	Settings	HIST	123 Sec	Nonchangeable Nonchangeable	User Administrator		
703	Backup Op Time	Total Backup Operation Time - Non-volatile history record. Default from factory is zero.	Settings	HIST	123 Sec	Nonchangeable Nonchangeable	User Administrator		

1600XP Command Parameters Table									
Cmd ID	Description on LCD	Brief Description	Location Map		Example	Rqd Security Level to change	By		
			Tab	Block					
704	UPS Lifetime	UPS Lifetime Remaining Time - Non-volatile history record. Default from factory is 61320 Hour	Settings	HIST	61320 Hr	Nonchangeable Nonchangeable	User Administrator		
705	Hi System Temp	Highest System Temperature Recorded - Non-volatile history record. Default from factory is 0 C.	Settings	HIST	0 C	Nonchangeable Nonchangeable	User Administrator		
706	Hi Battery Temp	Highest Ambient Temperature Recorded - Non-volatile history record. Default from factory is -15 C.	Settings	HIST	-15	Nonchangeable Nonchangeable	User Administrator		
707	Total VIUVs	Total No. Of Input Undervoltage - Non-volatile history record. Default from factory is 0.	Settings	HIST	0	Nonchangeable Nonchangeable	User Administrator		
708	Total OLS	Total No. Of Overload - Non-volatile history record. Default from factory is 0.	Settings	HIST	0	Nonchangeable Nonchangeable	User Administrator		
709	Total Tests	Total No. Of Tests - Non-volatile history record. Default from factory is 0	Settings	HIST	0	Nonchangeable Nonchangeable	User Administrator		
710	Test Record	Test Record - Detail View at Record Tab	Settings	HIST		Nonchangeable Nonchangeable	User Administrator		
711	Total Backups	Total No. Of Backup - Non-volatile history record. Default from factory is 0	Settings	HIST	0	Nonchangeable Nonchangeable	User Administrator		
712	Backup Record	Backup Record - View at Record Tab	Settings	HIST		Nonchangeable Nonchangeable	User Administrator		
713	Total Faults	Total No. Of Fault - Non-volatile history record. Default from factory is 0	Settings	HIST	0	Nonchangeable Nonchangeable	User Administrator		
714	Fault Record	Fault Record - Detail View at Record Tab	Settings	HIST		Nonchangeable Nonchangeable	User Administrator		
715	Total Operations	Total No. Of Operation - Non-volatile history record. Default from factory is 0	Settings	HIST	0	Nonchangeable Nonchangeable	User Administrator		
716	Operation Record	Operation Record - Detail View at Record Tab	Settings	HIST		Nonchangeable Nonchangeable	User Administrator		

1600XP Command Parameters Table									
Cmd ID	Description on LCD	Brief Description	Location Map		Example	Rqd Security Level to change	By		
			Tab	Block					
719	Total Warnings	Total No. Of Warning	Settings	HIST	0	Nonchangeable Nonchangeable	User Administrator		
720	Warning Record	Warning Record - Detail View at Record Tab	Settings	HIST		Nonchangeable Nonchangeable	User Administrator		
721	Total Sys Change	Total No. of System Changes	Settings	HIST	0	Nonchangeable Nonchangeable	User Administrator		
722	Sys Change Record	System Changes Record - Detail View at Record Tab	Settings	HIST		Nonchangeable Nonchangeable	User Administrator		
725	Total Resets	Total UPS Resets Since Initial Startup	Settings	HIST	4	Nonchangeable Nonchangeable	User Administrator		
726	Reset Record	View the reset records	Settings	HIST	See Records Tab	Nonchangeable Nonchangeable	User Administrator		
801	DFW Ver	Display Firmware Version	Settings	D&R	UH3DFV2001	Nonchangeable Nonchangeable	User Administrator		
802	DFW BDate	Display Build Date	Settings	D&R	Sep 30 2009	Nonchangeable Nonchangeable	User Administrator		
803	DFW BTime	Display Build Time	Settings	D&R	16:45:42	Nonchangeable Nonchangeable	User Administrator		
804	DBS Ver	Display Bootsector Version	Settings	D&R	UH3DBS01000	Nonchangeable Nonchangeable	User Administrator		
805	DBL Ver	Display Bootloader Version	Settings	D&R	UH3DBL01000	Nonchangeable Nonchangeable	User Administrator		
807	TMRsleep	Display Sleep Timer - Non-volatile configuration.	Settings	D&R	3 Min	Changeable Changeable	User Administrator		
808	En buzzer	Enable buzzer - Non-volatile configuration. Default from factory is Enable	Settings	D&R	Enable	Changeable Changeable	User Administrator		
810	Call Disp	Enable Calibration of Touch Panel Display - If this is enabled, touch panel calibration will begin and end the user will be required to touch the target as accurately as possible	Settings	D&R	Disable	Changeable Changeable	User Administrator		
811	P1X Cali	Point#1 X Calibration	Settings	D&R	29372	Nonchangeable Nonchangeable	User Administrator		
812	P1Y Cali	Point#1 Y Calibration	Settings	D&R	29598	Nonchangeable Nonchangeable	User Administrator		

1600XP Command Parameters Table									
Cmd ID	Description on LCD	Brief Description	Location Map		Example	Rqd Security Level to change	By		
			Tab	Block					
813	P2X Cali	Point#2 X Calibration	Settings	D&R	3906	Nonchangeable Nonchangeable	User Administrator		
814	P2Y Cali	Point#2 Y Calibration	Settings	D&R	29798	Nonchangeable Nonchangeable	User Administrator		
815	P3X Cali	Point#3 X Calibration	Settings	D&R	3922	Nonchangeable Nonchangeable	User Administrator		
816	P3Y Cali	Point#3 Y Calibration	Settings	D&R	3038	Nonchangeable Nonchangeable	User Administrator		
817	P4X Cali	Point#4 X Calibration	Settings	D&R	29286	Nonchangeable Nonchangeable	User Administrator		
818	P4Y Cali	Point#4 Y Calibration	Settings	D&R	3028	Nonchangeable Nonchangeable	User Administrator		
821	1st Startup*	First time startup - If UPS is first time startup, Display will guide the user through those commands necessary to setup the UPS properly.	Settings	D&R	Disable	Nonchangeable Changeable	User Administrator		
839	Test Result	Displays results of selected system test.	Settings	D&R		Nonchangeable Nonchangeable	User Administrator		
850	Reye Ins Dat	DC	Monitor	D&R		Nonchangeable Nonchangeable	User Administrator		
851	Reye Ver	RemotEye Firmware Version	Monitor	D&R		Nonchangeable Nonchangeable	User Administrator		
852	Reye IP	RemotEye IP Address - If RemotEye Card is not available, the IP address will be blank.	Monitor	D&R	1.2.3.4	Nonchangeable Nonchangeable	User Administrator		
853	Reye Mask IP	RemotEye Mask IP Address - If RemotEye Card is not available, the Mask IP Address will be blank.	Monitor	D&R	1.2.3.4	Nonchangeable Nonchangeable	User Administrator		
854	Reye Gway IP	RemotEye Gateway IP Address - If RemotEye Card is not available, the Gateway IP Address will be blank	Monitor	D&R	1.2.3.4	Nonchangeable Nonchangeable	User Administrator		
855	SReye	Status of Remote Eye (Unknown, Idle, OK)	Monitor	D&R	Unknown, Idle, OK	Nonchangeable Nonchangeable	User Administrator		

1600XP Command Parameters Table							
Cmd ID	Description on LCD	Brief Description	Location Map		Example	Rqd Security Level to change	By
			Tab	Block			
856	REye Baud*	Remote Eye's Baud Rate - Non-volatile configuration. Default from factory is 57600.	Settings	D&R	57600	Nonchangeable Changeable	User Administrator
857	SReye Datlink	Status of Remote Eye's Data Link (UPS) (Unknown, Idle, OK)	Monitor	D&R	Unknown, Idle, OK	Nonchangeable Nonchangeable	User Administrator
858	SReye Netlink	Status of Remote Eye's Network Link (Unknown, Idle, OK)	Monitor	D&R	Unknown, Idle, OK	Nonchangeable Nonchangeable	User Administrator

Records

If the selected Record buffer has no records, the display will return the message “NO RECORD.”

Each record file can be accessed by pressing the labeled key, and the records paged through using the standard next record, previous record, first record, and last record control keys at the bottom of the touchscreen.

Samples of the five record screens and the data they record are shown below.

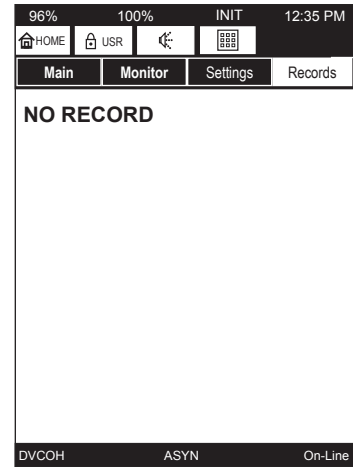

EMPTY BUFFER SCREEN

SAMPLE RECORD SCREENS

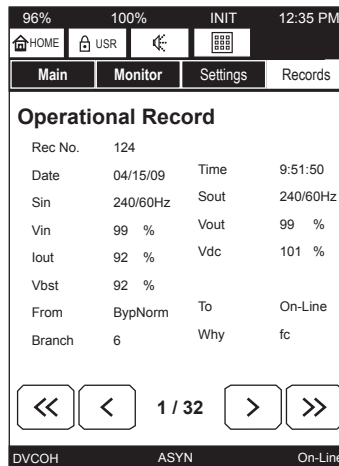
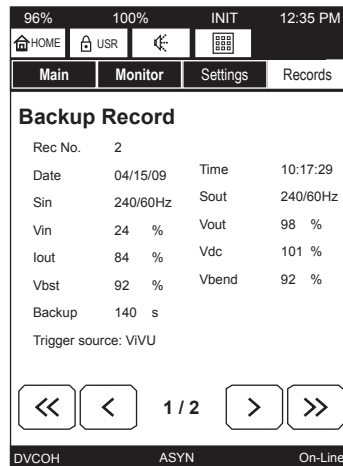
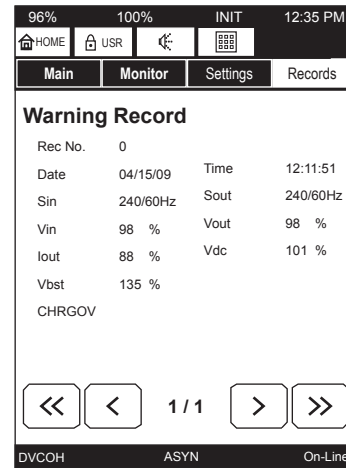
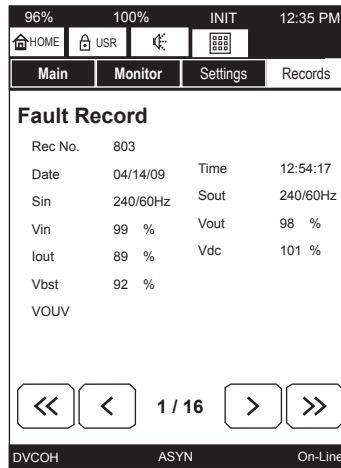
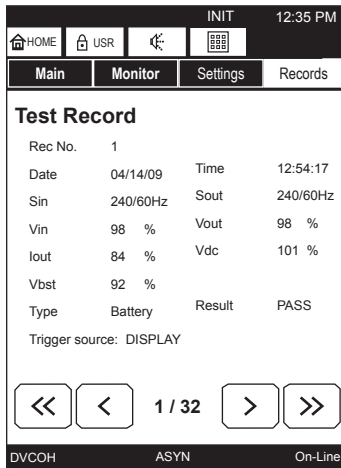

System Fault Messages

A Fault message is generated when either a fault condition occurs, or a warning condition occurs three times within ten minutes. The table below shows the possible fault messages and what actions need be taken.

If the input voltage is normal when the fault occurs then the UPS will switch immediately to the bypass mode to continuously feed power to the load.

If the fault condition occurs while the input power is abnormal and the UPS is in Bypass mode the UPS will shut down the output to prevent load equipment damage.

When a Fault condition exists, the red LED on the UPS display panel will illuminate until the fault is cleared.

Display	Meaning	Action
BYPOH	Bypass Overheat – Overheating condition occurred.	Check unit for blocked or in-operable fan. Lower ambient temperature if it is greater than 104 °F (40 °C). Bypass operation will also cease if overheat condition is not corrected within 1 hr. of inverter shutdown. Try restarting. If condition re-occurs plan for total shut-down and call for service.
BYPOL	Bypass Overload – UPS is overloaded.	Shut down excess equipment to reduce load.
CHRGOV	Charger Overvoltage – Charger overvoltage condition occurred.	UPS is possibly faulty. Check the UPS operation conditions at time of fault. Not advisable to restart the UPS. Call for service.
CLMT	Current Limit – Load on UPS output exceeds unit specifications.	Reduce load on UPS output.
DCIB	DC Bus Imbalance – DC voltage imbalance occurred.	Possible causes are UPS fault are connection of half-wave rectifier load. Check load and try restarting. If condition persists, call for service.
DCOC	DC Bus Overcurrent – DC overcurrent condition occurred.	UPS is possibly faulty. Check the UPS operation conditions at time of fault. Not advisable to restart the UPS. Call for service.
DCOV	DC Bus Overvoltage – DC overvoltage condition occurred.	UPS is possible faulty, input wiring error, input overvoltage or connection of a motor load. Try restarting. If condition persists call for service.
DCUVBS	DC Bus Undervoltage during Boostup Mode – DC Bus undervoltage condition occurred.	UPS is possibly faulty. Check the UPS operation conditions at time of fault. Not advisable to restart the UPS. Call for service.
DCUVC	DC Bus Undervoltage During Charging Mode – DC Bus undervoltage condition occurred.	UPS is possibly faulty. Check the UPS operation conditions at time of fault. Not advisable to restart the UPS. Call for service.
DVCOH	Device Overheat – Overheating condition occurred.	Reduce equipment load to 100% or less and try restarting.
FSOPEN	Fuse Open.	Replace fuse.
INVOLNR	Inverter Overload (Not Resettable) – Output overload condition occurred.	Reduce equipment load to 100% or less and manually restart the UPS.

INVOLR	Inverter Overload (Resettable) – Output overload condition occurred.	Reduce equipment load to 100% or less, the UPS will auto-restart.
OOC	Output Overcurrent – UPS is overloaded.	Shut down excess equipment to reduce load.
VOOV	Output Overvoltage – Output overvoltage condition occurred.	UPS is possibly faulty. Check the UPS operation conditions at time of fault. Not advisable to restart the UPS. Call for service.
VOUV	Output Undervoltage – Output undervoltage condition occurred.	UPS is possibly faulty. Check the UPS operation conditions at time of fault. Not advisable to restart the UPS. Call for service.

System Warning Messages

Warning messages are generated when a noncritical abnormal operating condition occurs. The following tables shows possible messages and their meaning.

When a Warning condition exists, the amber LED on the UPS display panel will flash for the duration of the Warning condition.

Display	Meaning	Action
AOH	Ambient Overheat – The unit is overheated (warning is given when the internal temperature reaches and exceeds 50° C ambient).	Check to see if the ambient temperature is greater than 104 °F (40 °C) If so, turn on air conditioning and check the ventilation fan at the back of the unit for operation or obstructions. Otherwise, shut down the unit and call for service.
ASYN	Asynchronous mode – Input and output frequency are different. Bypass is disabled.	No Action Needed.
BDEPL	Battery Depleted – Battery not within specifications.	Contact the nearest Toshiba authorized representative for service.
BLFE	Battery Lifetime End – Batteries at end of life.	Have batteries replaced immediately.
BLFN	Battery Lifetime Near End – Batteries are nearing the end of their expected lifetime.	Contact the nearest Toshiba authorized representative to arrange for battery replacement.
BOH	Battery Overheat – Battery not within specifications.	Contact the nearest Toshiba authorized representative for service.
BRPL	Replace Battery – Battery at end of life expectancy.	Replace battery immediately.
BSDV	Battery Shutdown Voltage – Battery is discharged down to minimum level.	UPS will shut down.
BTSTFL	Battery Test Failed – Battery not within specifications.	Contact the nearest Toshiba authorized representative for service.
BYPOV	Bypass Overvoltage – Bypass voltage exceeds UPS specifications.	Depends on UPS mode.

BYPUV	Bypass Undervoltage – Bypass voltage less than UPS specifications.	Depends on UPS mode.
CALL	Service Call Required – Inspection of the unit is advised.	Have inspection/service performed.
CHRGOV	Charger Overvoltage – Battery Charger not within specifications.	Contact the nearest Toshiba authorized representative for service.
CLMT	Current Limit – UPS not within specifications.	Contact the nearest Toshiba authorized representative for service.
DCER	Display Cable Error – Display cable is disconnected.	Connect the display cable.
DDCN	Communication Error between Display and Main Controllers.	Contact the nearest Toshiba authorized representative for service.
FBYPER	Bypass Frequency Error – Input frequency outside of UPS specifications.	Depends on UPS mode.
FIER	Input Frequency Error – Input frequency outside of 45-65 Hz range.	Depends on UPS mode.
LB	Low Battery – The battery level has dropped low (about 90% or less) during operation. Continued operation in this mode will deplete battery and cause output shut down.	Immediately shut down the load equipment in an orderly fashion and then press the STOP key.
OL110	Overload – UPS is overloaded (110% and above) Unit will switch to bypass operation or shut down if no action is taken.	Shut down excess equipment to reduce load.
RCER	Communication Error between RemoteEye and UPS.	Ensure RemoteEye is connected to UPS. Contact the nearest Toshiba authorized representative for service.
RSER	Communication Error at Service Port.	Contact the nearest Toshiba authorized representative for service.
RUER	Communication Error at LAN.	Contact the nearest Toshiba authorized representative for service.
VDCUVBT	DC Bus Undervoltage During Battery Test.	Contact the nearest Toshiba authorized representative for service.
VIOV	Input Overvoltage – Input voltage exceeds UPS specifications.	Depends on UPS mode.
VIUV	Input Undervoltage – Input voltage less than UPS specifications.	Depends on UPS mode.

System Mode Messages

A UPS Mode message is generated when the UPS changes operating mode. The following tables list the possible operating modes for the UPS.

Display	Meaning
Backup	Backup – Power comes from other than input.
BattTest	Battery Test – Battery test in progress.
Bypass	Bypass – UPS is offline, power is being provided directly from UPS input.
On-Line	On-Line – Input converter and inverter are running (Double conversion mode).
Shutdown	Shutdown – No output, DC Bus is charged through Softstart Resistor.
Startup	Startup – UPS is starting up.

System Status Messages

A UPS Status message is generated when the UPS changes its status (from inverter to bypass mode, for example). The table below shows the possible Status messages and their meaning.

Display	Meaning	Action
BYP	Bypass mode – Power is supplied by UPS input.	No action needed.
CHRGERR	Charger Error – Charger overvoltage error.	Contact the nearest Toshiba authorized representative for service.
DLYST	Delay Start – UPS is counting down prior to startup.	No action needed.
EE1ST	EEPROM is loaded with default values.	No action needed.
EE2RAERR	EEPROM to RAM loading Error.	Contact the nearest Toshiba authorized representative for service.
EEUPERR	EEPROM updating Error.	Contact the nearest Toshiba authorized representative for service.
EPO	EPO circuit is active.	Reset EPO switch to start.
FIERRST	Frequency Input Error Start – Input frequency could not be detected and UPS starts up with default EEPROM setup.	Ensure correct input frequency is selected in UPS settings.
FLT	A fault has occurred.	See Fault records.
FWUPERR	Firmware Update Error.	Contact the nearest Toshiba authorized representative for service.
INIT	Initialization – UPS is initalizing.	No action needed.
INV	Inverter mode.	Inverter is running (it can be On-Line, Battery Test, or Backup)
LANSD	UPS goes to Shutdown triggered from LAN SD circuit.	Deactivate LAN shutdown signal to reset.

LB	Low Battery – The battery level has dropped low (about 90% or less) during operation. Continued operation in this mode will deplete battery and cause output shut down.	Immediately shut down the load equipment in an orderly fashion and then press the STOP key.
PFAIL	Input power failure.	No action needed.
RMTSD	Remote shutdown occurred.	Disconnect LAN signal to reset.
RO2EEERR	ROM to EE Loading Error.	Contact the nearest Toshiba authorized representative for service.
SYNC	Synchronous mode.	Input and output are synchronized.
TIMEDSD	UPS is counting down prior to shutdown.	Immediately shut down the load equipment in an orderly fashion and then press the STOP key.
WRN	A warning has occurred.	See Warning record.

UPS Protection System

System Protection Features

The following schematic shows the electrical locations of the protection devices on the UPS.

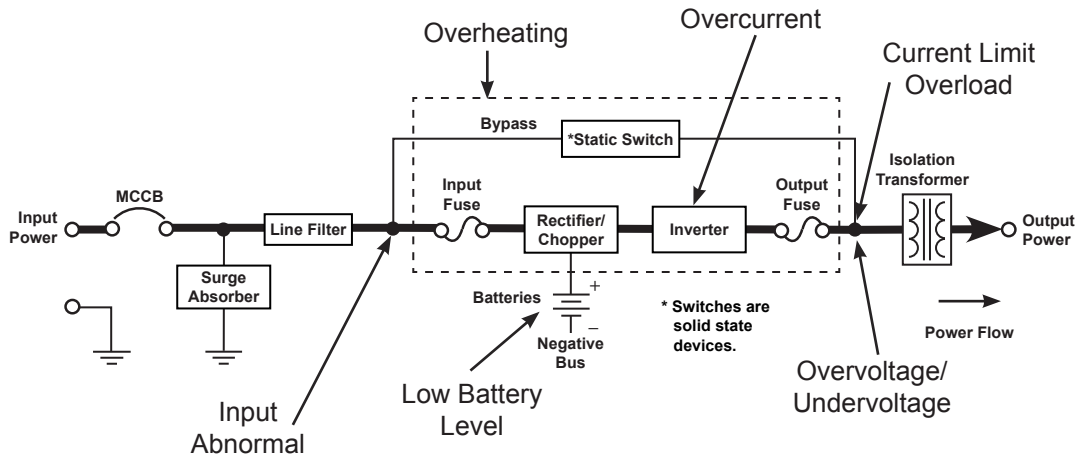

System Protection Functions

The following charts show the built-in system fault protection functions on all the UPS models.

BUILT-IN UPS FAULT PROTECTION FUNCTIONS

Protection Item	Output Overvoltage	Output Undervoltage	Output Overload
LCD Message	OUT-OV	OUT-UV	OVERLOAD
Cause	Control malfunction; chip error	Control malfunction; Fuse opened; Load issue	Overload – Short circuit at load
Operation Mode After Fault	Bypass operation – Chopper and inverter are stopped		Inverter OL: Transfer to bypass; Bypass OL: Inverter, chopper stopped
Audible Alarm	Yes – Continuous buzzer		See Audible Alarm Functions on page 31
Visible Alarm	Red Fault LED on		Inverter OL: Fault lamp off Bypass OL: Fault lamp on
Relay Contact Alarm	Fault relay closed Bypass relay closed		Fault relay open; Inverter OL: Bypass relay closed Bypass OL: Bypass relay open
Auto-retransfer	No		Inverter OL: Yes if bypass is OK Bypass OL: No

BUILT-IN UPS FAULT PROTECTION FUNCTIONS (CONT'D)

Protection Item	Internal Overheat	DC Circuit Overvoltage	DC Circuit Overcurrent
LCD Message	OVERHEAT	DC-OV	DC-OC
Cause	Fan failure; High ambient temperature	Chopper malfunction	Inverter/chopper fault
Operation Mode After Fault	Shutdown – No output	Bypass operation – Chopper and inverter are stopped Inverter OL – Transfer to bypass	
Audible Alarm	Yes – Continuous buzzer		
Visible Alarm	Red Fault LED on		
Relay Contact Alarm	Fault relay closed Bypass relay closed		
Auto-retransfer	No		

Preventive Maintenance/Parts Replacement

Preventive Maintenance

Toshiba 1600XP Series of uninterruptible power systems have been designed to provide years of trouble-free operation requiring a minimum of preventive maintenance.

The best preventive measure that the UPS user can take is to keep the area around the unit, particularly the air inlet vents, clean and free of moisture and dust accumulations. If the atmosphere of the installation site is very dusty, use a vacuum cleaner to periodically remove dust accumulations around and from the unit.

 CAUTION
<p>Only a qualified Toshiba representative should be allowed to perform any routine maintenance or service on this equipment other than those preventive maintenance details which are described directly above this caution.</p>

Cleaning the Touchscreen

The touchscreen display is covered with a protective Teflon coating. It should be cleaned with a clean, damp cotton cloth to avoid scratching the coating.

Parts Replacement

The following list shows recommended intervals for periodic replacement of certain UPS parts:

1. Aluminum electrolytic capacitors: Replace once every 5 years.
2. Fuses: Replace once every 7 years.
3. Cooling fan: When operated in an ambient temperature of 86 °F (30 °C) to 104 °F (40° C), replace every 3.5 years. When operated in an ambient temperature of less than 86 °F (30 °C) , replace every 5 years.

NOTE: The cooling fans are not hot swappable. Remove all power from the UPS before replacing the cooling fans.

(Open the UPS main circuit breaker, disconnect external battery cabinets, and partially slide out the top battery trays enough to open the internal DC power circuit.)`

4. Batteries: In order to maintain system reliability, the UPS batteries should be replaced on a regular schedule. To ensure reliable operation, all of the batteries should be replaced at the same time. Use the following chart for replacement:

UPS BATTERY REPLACEMENT

BATT AMB TEMP*	AVERAGE LIFETIME
68 – 77 °F (20 – 25 °C)	Approximately 5 yrs.
86 °F (30 °C)	Approximately 3.5 yrs.
95 °F (35 °C)	Approximately 2.5 yrs.
104 °F (40 °C)	Approximately 1.8 yrs.
113 °F (45 °C)	Approximately 1.25 yrs.

* Continual operation at ambient temperatures above 25 °C will degrade the battery life.

Optional Receptacle Panel Installation Instructions

These are the instructions for installing the optional Modular Output Receptacle Panels for the 1600XP Series UPS. These instructions apply to all UH3-RP-XX panel options.

WARNING: The work outlined in these instructions is to be performed only on a completely un-energized UPS system.

Refer to Figure 1 for location of UPS referenced material. Refer to Figure 2 for material referring to the receptacle panel module. There are different panels available depending on the UPS typeform.

Step 1: Remove the modular receptacle panel cover plate.

On the rear of the UPS, locate the cover plate for the receptacle panel module interface (see Figure 1).

Remove the 6 mounting screws.

Remove the cover plate. A square-shaped plug will be exposed.

Step 2: Snap-In Output Receptacle modular panel.

Carefully mate the square-shaped connector on the UPS to its matching counter part on the rear of the modular panel.

Step 3: Mount the receptacle panel.

Attach the screws removed from the cover plate through the mounting holes of the receptacle panels and back into the UPS mounting points.

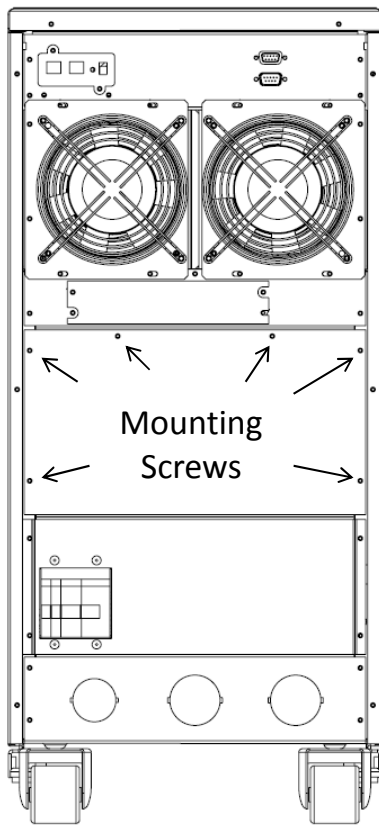

Figure 1

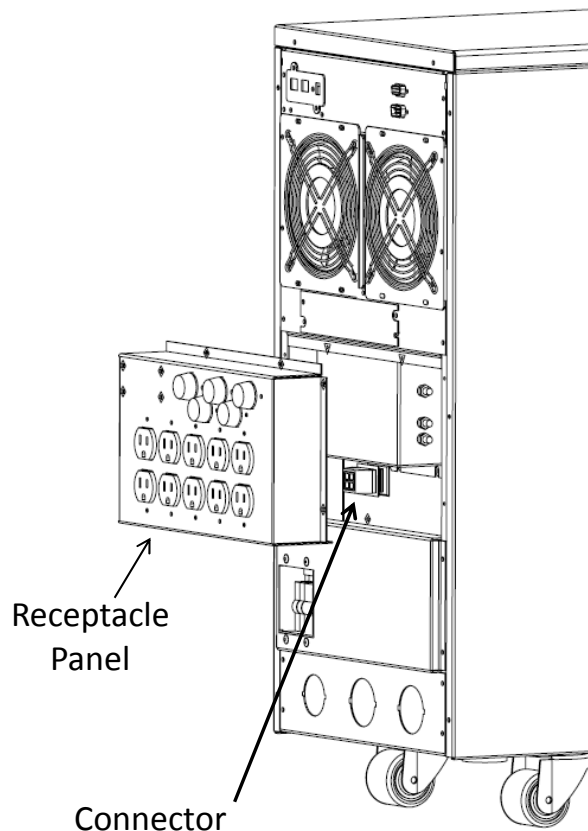
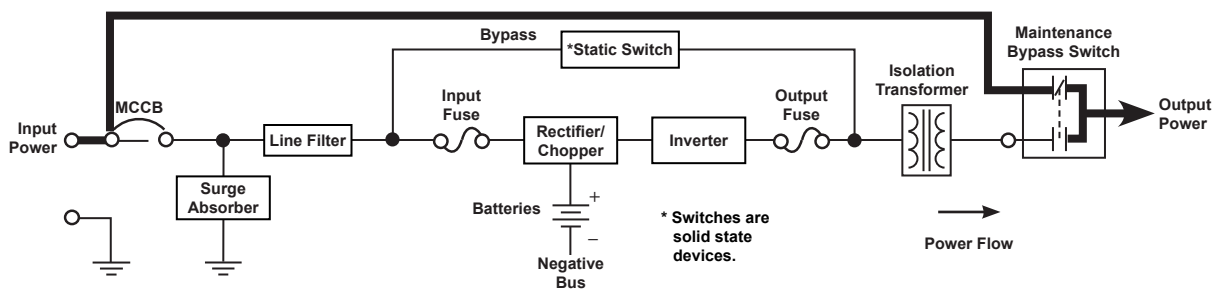

Figure 2

Optional MB (Maintenance Bypass) Units

The following illustration shows the circuit power flow when the UPS is operating in the optional Maintenance Bypass mode. The input jumper on the UPS must be set for 240 VAC.

NOTICE
Ensure the UPS is in Static Bypass before switching the unit from UPS to Maintenance Bypass mode or from Maintenance Bypass to UPS mode. Failure to do so could result in damage to the maintenance bypass switch or the UPS.
This Maintenance Bypass unit can only be used for 240 V applications. Ensure the UPS voltage selector jumper is set to 240 V. See page 13 for the correct 240 V setting.



POWER FLOW IN MAINTENANCE BYPASS MODE FOR ALL MODELS

Internal Maintenance Bypass

The optional internal maintenance bypass is mounted on the rear of the UPS.

Internal Maintenance Bypass Instructions:

From Inverter Mode to Maintenance Bypass Mode

1. Turn the RUN/STOP switch to the STOP position on the UPS.
2. Turn the Maintenance Bypass Switch to the Bypass position. The Bypass LED should be ON and the UPS LED should be OFF. The LEDs are next to the Maintenance Bypass switch, on the back of the UPS.
3. Turn the MCCB input breaker on the UPS to the OFF position. The UPS is now operating in Maintenance Bypass Mode.

From Maintenance Bypass Mode to Inverter Mode

1. Turn the MCCB input breaker on the UPS to the ON position.
2. Turn the Maintenance Bypass switch to the UPS position. The UPS LED should be ON and the Bypass LED OFF.
3. Turn the RUN/STOP switch to the RUN position on the UPS. The UPS is now operating in the UPS Mode.

External Maintenance Bypass

Wiring

The following connections must be made to the Utility Panel and the Load Panel. The Main UPS output is located on the terminal block on the back of the UPS. (TB-4(X1) and TB-7(X3) 240 VAC.)

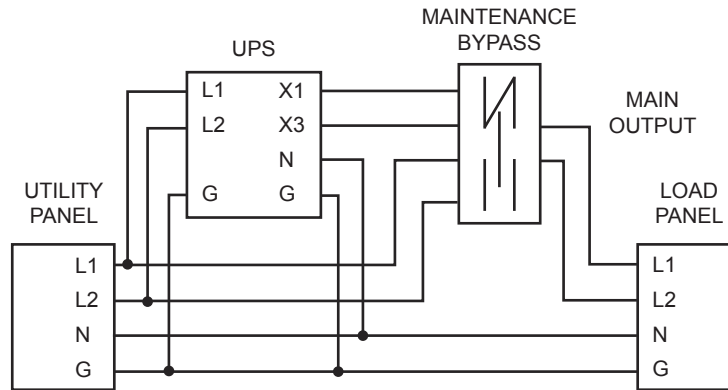

See the application instructions included with the External Maintenance Bypass Unit for wiring details.

External Layouts/Dimensions/Shipping Weights

Dimensional Data

DIMENSIONAL DATA							
	3.6 kVA	6 kVA	8 kVA	10 kVA	14 kVA	18 kVA	22 kVA
A	22.1 in. (561 mm)	27.5 in. (698 mm)	28.3 in. (719 mm)	28.3 in. (719 mm)	39.0 in. (991 mm)	39.0 in. (991 mm)	39.0 in. (991 mm)
B	10.0 in. (254 mm)	10.0 in. (254 mm)	13.0 in. (330 mm)	13.0 in. (330 mm)	17.5 in. (445 mm)	17.5 in. (445 mm)	17.5 in. (445 mm)
C	34.0 in. (863 mm)	34.0 in. (864 mm)	34.9 in. (886 mm)	34.9 in. (886 mm)	36.1 in. (917 mm)	36.1 in. (917 mm)	36.1 in. (917 mm)
D	19.7 in. (500 mm)	25.1 in. (637 mm)	25.7 in. (654 mm)	25.7 in. (654 mm)	35.6 in. (904 mm)	35.6 in. (904 mm)	35.6 in. (904 mm)
E	2.4 in. (61 mm)	2.4 in. (61 mm)	2.6 in. (65 mm)	2.6 in. (65 mm)	3.4 in. (87 mm)	3.4 in. (87 mm)	3.4 in. (87 mm)

Electrical Conduit Knock-out Data

ELECTRICAL CONDUIT KNOCK-OUT HOLE SIZES (DIAMETER)						
3.6 kVA	6 kVA	8 kVA	10 kVA	14 kVA	18 kVA	22 kVA
3 ea. Back/ Bottom 1.125 in. (28.575 mm)	3 ea. Back/ Bottom 1.125 in. (43.69 mm)	2 ea. Back/ 3 ea. Bottom 1.72 in. (43.69 mm)	2 ea. Back/ 3 ea. Bottom 1.72 in. (43.69 mm)	4 ea. Back/ Bottom 1.72 in. (43.69 mm)	4 ea. Back/ Bottom 1.72 in. (43.69 mm)	4 ea. Back/ Bottom 1.72 in. (43.69 mm)
–	–	1 ea. Back 1.5 in. (38.1 mm)	1 ea. Back 1.5 in. (38.1 mm)	–	–	–

Unit and Shipping Weights

Model	Unit Weight		Shipping Weight	
	Pounds	Kilograms	Pounds	Kilograms
3.6 kVA	250	113	325	147
6 kVA	288	130	395	179
8 kVA	466	211	533	242
10 kVA	491	223	527	239
14 kVA	784 ¹	355 ¹	835 ¹	376 ¹
18 kVA	784 ¹	355 ¹	904 ¹	410 ¹
22 kVA	784 ¹	355 ¹	904 ¹	410 ¹

1. Subject to change without notice.

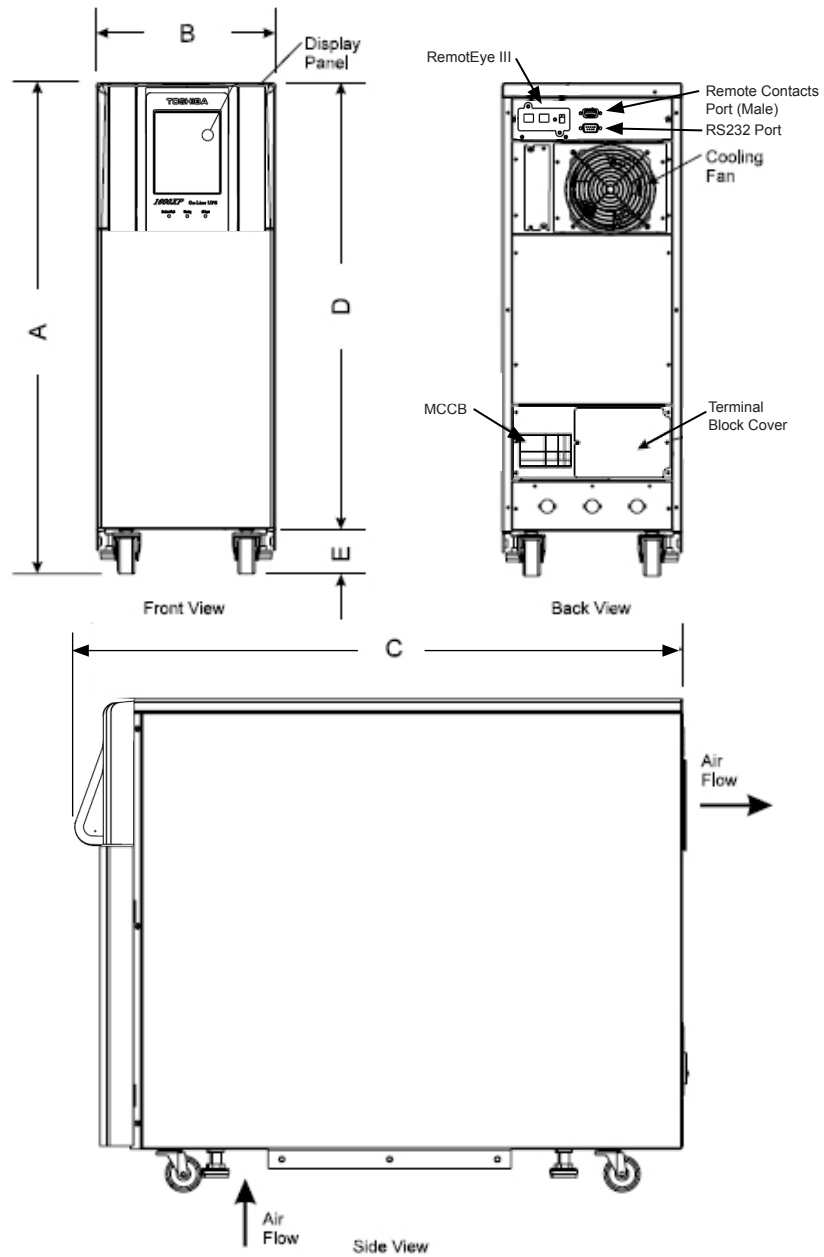

External Layout for 3.6kVA and 6kVA units

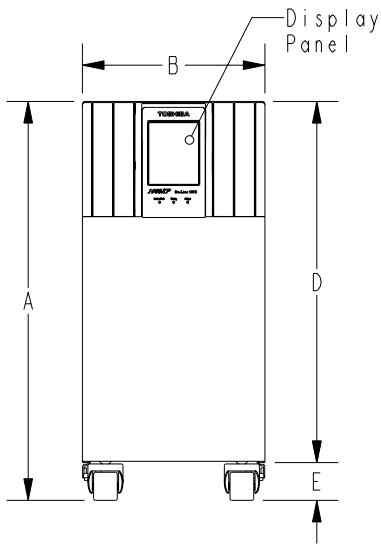

Front View

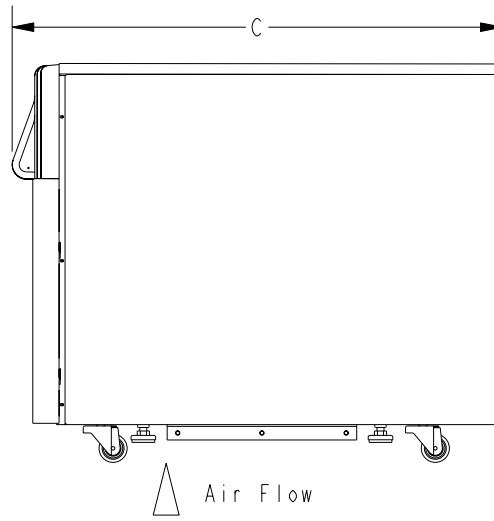

Side View

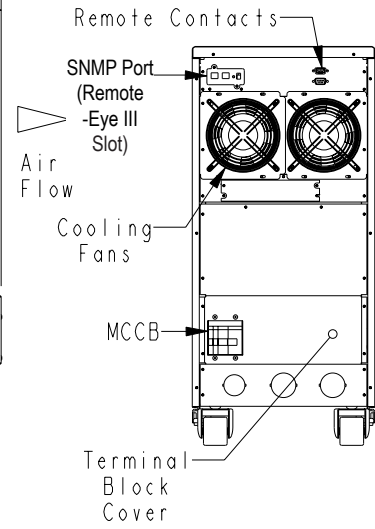

Back View

External Layout for 8kVA and 10kVA units

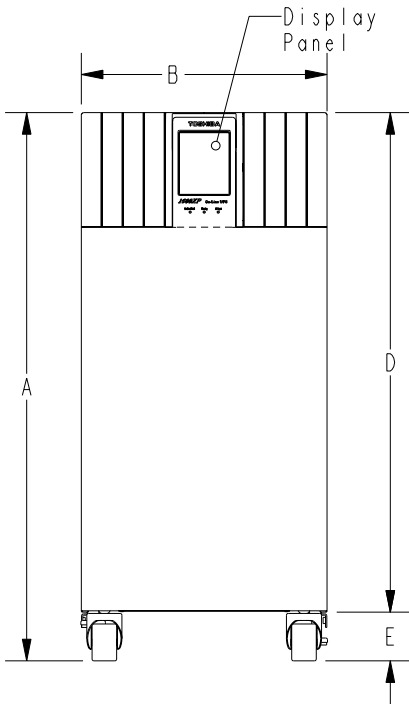

Front View

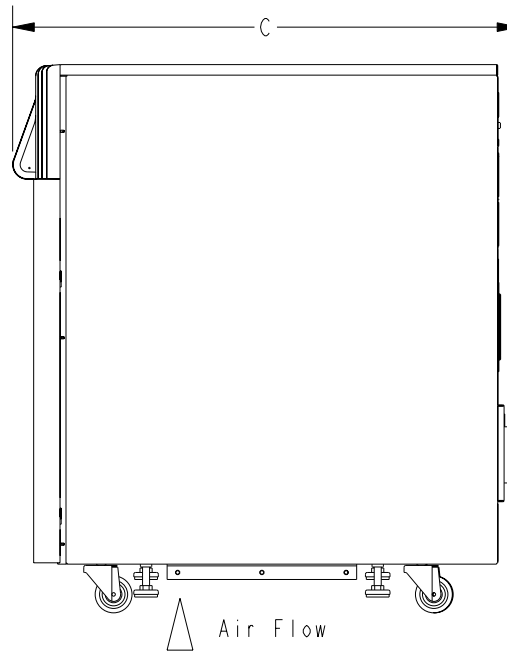

Side View

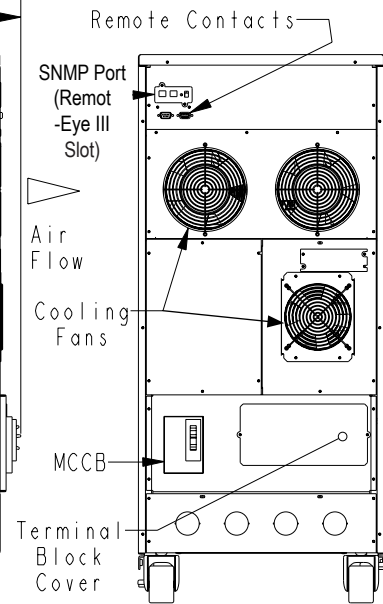

Back View

External Layout for 14kVA, 18kVA and 22kVA units

Index

A

- AC input mode 29
- Altitude 20, 23
- Application 5
- Audible alarm 5, 58, 59
 - functions 31
- Automatic Retransfer 23

B

- Backup mode 30
- Battery
 - backup mode 30, 31
 - backup time 19, 22, 26, 30
 - disposal 6
 - lifetime 23
 - low-voltage tolerances 26
 - manufacturer 24
 - pack 24
 - Pack (quantity) 24
 - recharge tolerances 28
 - recharging 28
 - replacement 3, 23, 60
 - voltage drop 5, 16, 30
- Battery Cabinet 15
- Buzzer volume 23
- Bypass
 - disable 23
 - mode 27, 29, 37
 - overload capacity 22

- switch 23

C

- Cable size 14
- capacitors 60
- Common-mode noise 5, 22
- Communication interface 16
- Conduit Knock-out, sizes 64
- Cooling fan 60

D

- Data. *See* Data Display Screens, Data Setting Screens
- DB9 Connector
 - female pinouts 18
 - male pinouts 16
- Dimensional Data 64, 66
- Display
 - Adjustment 32
- Disposal 6

E

- Emergency Power Off (EPO) function 14, 30
- Enclosure 24
- Environment 6, 23
- Event Data Storage 23

F

- fan 24, 59
- Fault
 - protection functions 58, 59
 - signal 16, 29, 31
- Frequency

AUTO/MAN 22
input 22
output 22
Warning 10
Front Panel layout 32, 33, 36, 38, 39

G

ground
 Importance of, 7
 terminals 14
ground
 RS-232C 18
Grounding 9

H

Humidity 23
humidity 6

I

Input Capacity 22
Input Frequency 22
 warning 10
Input Voltage 19, 20, 21, 22, 23, 24
 requirements 10
Inspection 6
Installation Precautions 7
Interface
 communications 16, 17, 18
 receptacle panel module 61
 RS232 ASCII 23
Inverter Overload Capacity 22

K

Keypad
 controls 38
 password 39
Keys 34
Knock-out, sizes 64

L

labels, warning 11
Lifetime
 battery 23, 60
 capacitors, Aluminum electrolytic 60
 fan, cooling 60
 fuses 60
Liquid Crystal Display (LCD) Functions 32
Low Voltage Tolerance 26

M

MAIN tab 36
Maintenance Bypass 62, 63
Maintenance Bypass, voltage restrictions 62
Maintenance Bypass Unit 62
maximum ambient operating temperature 3
Mimic display 40
Mode
 AC Input 29
MONITOR tab 40

N

Normal input power supply 16

O

Off 32
Operation modes. *See* Modes

output disconnect 3
Overload Capacity 22
Overvoltage
 DC 59
 output 58

P

Parameters
 changing 44, 46
Passwords 39
Peak Output Current 22
Power Backup 5
Power Conditioning 5
Power factor
 output, rated load 26
Power factor
 input 22
 output, rated load 22
Power failure signal 16, 17
Precautions 10
Preventive Maintenance 59
Protection System 58

R

Real Time Clock 23
Receptacle Panels 60, 61
Recharge Time 22, 28
RECORDS tab
 Fault messages 53
 Mode messages 56
 Status messages 56
 Warning messages 54
relay switch 16

remote contacts interface 16
Remote Switch 14
RemotEye Network Card 18
Restrictions on UPS use 10
RS-232C 18
Run 32

S

Safety instructions 1, 3
Schedule Operation 23
Security
 access 39
 passwords 39
Security access 46
SETTINGS tab 42
 parameters 46
Shipping Weight 64
Shutdown voltage 26
Signal Function
 RS-232C 16
Signal Words 2
Size
 battery packs 24
 UPS dimensions 24
 wire 14
Specifications 19
Starting the UPS 27, 37
Startup, Initial 25
Stopping the UPS 27, 32
Stop Signal Operation 17
Storage 6, 23
 temperature 23

T

Terminal Block 13, 15

Theory of Operation 5

torque, tightening 14

Touchscreen

 calibrate 45

 control icons 34

 keypad 38

 layout 33

 menu tree 36

 mimic display 40

 passwords 39

 screen disable 37

U

Unpacking 6

UPS

 Discharge Process 26, 30

UPS Connections 13

UPS functional overview 5

UPS stop signal input 16, 17

V

ventilation 10

Voltage Transient 22

Volume, Buzzer. *See* Buzzer Volume

W

warning labels 11

Warranty d, e, 6

Weights, shipping 64

Weights, UPS 64

TOSHIBA

TOSHIBA INTERNATIONAL CORPORATION

INDUSTRIAL DIVISION

13131 West Little York Road, Houston, Texas 77041

Tel. (713) 466-0277 Fax. (713) 466-8773

US (800) 231-1412 Canada (800) 872-2192 Mexico 01/800/527-1204

www.Toshiba.com/ind

Printed in the U.S.A.