

## Uninterruptible Power Systems



*New  
Display*

# 1600XP Series

3.6 to 22 KVA Single-Phase

**3** Year  
Warranty

- True On-Line, Double-Conversion UPS
- Input Power Factor > 0.95
- Input Current THD < 5%
- Wide Input Voltage Window +10% to -30%
- Wide Input Frequency Window 45 to 65 Hz
- 0.85 Output Power Factor
- Hot-Swappable Battery Packs & Cooling Fans
- Internal Isolation Transformer
- External Battery Connector
- Generator Compatible
- Crest Factor 3.0
- Three-Year Warranty

## *Enhanced Features!*

- *User-Friendly, Programmable Touch-Screen Display*
- *Angled Terminal Block for Ease of Installation*
- *RoHS and CE Certification*

# 1600XP Series 3.6 to 22 KVA UPS

Capacity	3.6 KVA (3.1 KW)	6 KVA (5.1 KW)	8 KVA (6.8 KW)	10 KVA (8.5 KW)	14 KVA (11.9 KW)	18 KVA (15.3 KW)	22 KVA (18.7 KW)
Topology	True On-Line, Double Conversion; IGBT Power Factor Corrected Input; Internal Isolation Transformer						
Certifications	UL 1778, CUL, CE, FCC Class A, IEEE 587, ANSI/C62.41, ISO 9001, ISO 14001, NEMA/PE1-1993, RoHS						
<b>Input Characteristics</b>							
Input Voltage	Single-Phase 208/240 VAC (Three-Wire Input/L-L, G); 230 VAC (Three-Wire Input/L, N, G), +10% -30%						
Input Frequency	45 to 65 Hz (Auto-Sensing)						
Input Power Factor	> 0.95 For All Loads						
Input Current THD	< 5% (Even for 100% Non-Linear Loads)						
AC Input Breaker Rating	30 A	50 A	60 A	63 A	100 A	100 A	125 A
<b>Battery Characteristics</b>							
Battery Type	Valve-Regulated Lead Acid; Flame Retardant (9.0 Amp Hr)						
Backup Time (Fully Charged)	7 Minutes	7 Minutes	7 Minutes	5 Minutes	7 Minutes	5 Minutes	3 Minutes
Recharge Time	0.85 Power Factor; 77° F; Approximately 30% More Runtime for Output Power Factor of 0.7 (Triple Backup Time at ½ Load)						
DC Link	144 VDC	216 VDC			288 VDC		
<b>Output Characteristics</b>							
Output Voltage	Single-Phase 240/208/120 VAC (Four-Wire Output/L-L, N, G) 230 VAC (Three-Wire Output L, N, G)						
Output Voltage Regulation	±3%; ±1% Typical						
Output Frequency	50/60 Hz; ±0.5 Hz/1.0 Hz/1.5 Hz (Factory or Authorized Service Center Selectable)						
Output Voltage THD	< 3% for Linear Load; 1% Typical						
Common Mode Noise	< 0.5 V RMS						
Rated-Load Power Factor	0.85 (0.6 to 1.0) Lag						
Rated Output Current @ 240 V	15 A	25 A	33.3 A	41.6 A	58 A	75A	91.6 A
Maximum Peak Output Current	45 A	75 A	100 A	125 A	174 A	225 A	275 A
Overload Capacity	Inverter Mode: 150% for 10 Seconds, 125% for 30 seconds; Bypass Mode: 125% for 10 Minutes, 1000% for One Cycle						
<b>Environmental Characteristics</b>							
Efficiency (AC-DC-AC)	> 85%						
Temperature Range	0 to 40°C (Operating); -20° to +40°C (Storage)						
Heat Generation (BTU/Hr)	1843	3071	4095	5118	7168	9213	11,260
Altitude	6600 Feet (2000 Meters) Maximum Without Derating						
Audible Noise	< 60 DBA @ 1 Meter						
<b>Mechanical Design</b>							
Enclosure	Steel Enclosure; Complies with NEMA 1 and UL Type-1 Standard						
Enclosure Dimensions (HxWxD)	22.1" x 10" x 33"	27.5" x 10" x 33"	28.4" x 13" x 34.9"		39.1" x 17.5" x 36.1"		
Shipping Weight	280 lb/127 kg	346 lb/157 kg	476 lb/214 kg		784 lb/355 kg	784 lb/355 kg	835 lbs/379 kg
Battery Pack Size (HxWxD)	5" x 7.3" x 19" (Battery Pack Part # 51896-FS)						
Battery Pack Quantity	Two	Three	Four		Eight		
<b>Additional Key Features</b>							
Output Isolation Transformer, RS232 & Dry Contact Interface, Crest Factor of 3, Angled Terminal Blocks for Easy Installation, Casters for Mobility							
<b>Options</b>							
SNMP & WEB-Based Monitoring	RemotEye® III, RemotRadar™, & Environmental Monitoring Device						
Matching Battery Cabinet	Consult Factory						
Internal/External Maintenance Bypass	Consult Factory						
Receptacle Panel & Line Cord	Consult Factory						
<b>Warranty</b>							
Three Years on Electronics (UPS); Two Years on Battery (See Toshiba Warranty Policy for Full Details)							

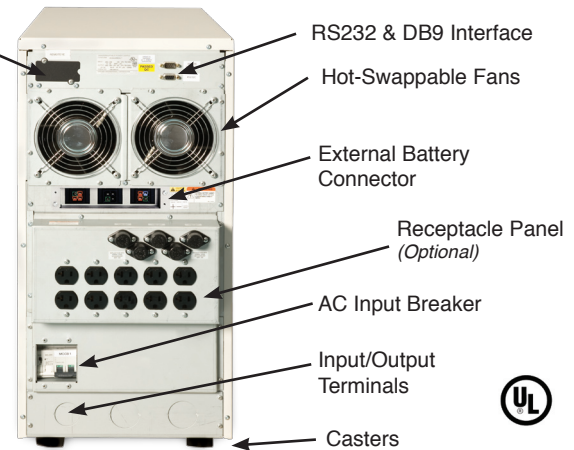
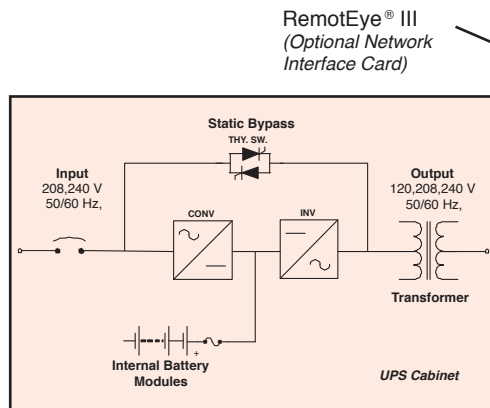

**UPS    ADJUSTABLE SPEED DRIVES    MOTORS    CONTROLS    INSTRUMENTATION    PLC**

# TOSHIBA

TOSHIBA INTERNATIONAL CORPORATION

**INDUSTRIAL DIVISION**

13131 West Little York Road, Houston, Texas 77041  
 Tel 713/466-0277 Fax 713/466-8773  
 US 800/231-1412 Canada 800/872-2192 Mexico 001/800/527-1204  
 www.toshiba.com/ind  
 Copyright 4/2010

Available Through:

**PERFORMANCE**  
 TECHNOLOGY SOLUTIONS  
 Performance Technology Solutions  
 P: 303.697.8687 F: 888.412.2565  
 info@ptsups.com www.ptsups.com

